

DG Flugzeugbau GmbH
Otto-Lilienthal-Weg 2 / Am Flugplatz • D-76646 Bruchsal • Germany
Postbox 1480, D-76604 Bruchsal • Germany
Tel. 07251/3020-100 • Telefax 07251/3020-200 • eMail: dg@dg-flugzeugbau.de
Spare part and material sales: Tel. 07251/3020-270 • lager@dg-flugzeugbau.de
www.dg-flugzeugbau.de

FLIGHTMANUAL
FOR THE
MOTORGLIDER
DG-1000T

Type: DG-1000
Variant: DG-1000T
Data Sheet No.: EASA.A.072

Factory Serial No.: _____

Registration No.: _____

Date of Issue: July 2005

Pages as indicated by "App." are approved by:

(Signature)

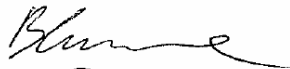

(Authority)



(Stamp)

(Original date of approval) 25. JAN. 2006

This motorglider is to be operated in compliance with information and limitations contained herein.

Flight manual DG-1000T

Warnings and hints

- All motorgliders are very complex technical devices. If you don't use yours as it is intended and within the certified operating limitations or if you fail to carry out proper maintenance work, it may harm your health or place your life in danger.
- Prior to flying the aircraft read all manuals carefully and regard especially all warnings, caution remarks and notes given in the manuals.
- Never take-off without executing a serious pre-flight inspection according to the flight manual!
- Always respect the relevant safety altitudes!
- Respect the stall speeds and always fly with a safety margin above the stall speed according to the flight conditions, especially at low altitudes and in the mountains.
- Use only the battery chargers as specified in the flight manual.
- Don't execute yourself any work on the control system except for greasing.
- Repairs and maintenance work should only be accomplished by the manufacturer or at certified repair stations rated for this type of work. A list of stations which have experience with DG aircraft may be obtained from DG Flugzeugbau.
- Even if no annual inspections are required in your country, have your aircraft checked annually, see maintenance manual section 2.
- Please pay attention to our web-site www.dg-flugzeugbau.de. There you will find the latest technical notes and service information for your glider: www.dg-flugzeugbau.de/tech-mitteilungen-e
The „DG Pilot Info“ informs you immediately by e-mail about the publication of new technical notes and service information.
If you don't receive this info service, please send a mail to weber@dg-flugzeugbau.de with subject "DG Newsletter please" to receive this service free of charge.

Issued: June 2005

Flight manual DG-1000T

0 Revisions

0.1 Record of revisions

Any revision of the present manual, except actual weighing data, must be recorded in the following table and in case of approved sections endorsed by the responsible airworthiness authority.

The new or amended text in the revised page will be indicated by a black vertical line in the right hand margin, and the Revision No. and the date will be shown on the bottom left hand of the page.

Rev. No.	Affected Pages/section	Description	Issue Date	EASA Approval Date	Inserted Date Signature
1	0.5, 7.14, 7.15	TN1000/09	October 2006	12.12.2006	
2	0.3-0.5, 1.5, 1.6, 2.5, 2.11, 2.12, 2.14, 2.15, 3.3, 4.13, 4.16-4.18, 4.21, 4.24, 4.25, 5.3, 5.5-5.8, 6.6, 6.8	TN1000/10 Manual revision	January 2007	March 27. 2007	
3	0.3 – 0.5, 2.12, 4.6, 4.12, 4.13, 7.14 – 7.17	TN1000/11 Manual revision	October 2007	5. Dec. 2007	
4	0.1, 0.4, 0.5, 4.9, 4.17, 7.5	landing gear positive locking device TN1000/13	February 2008	28. April 2008	
5	0.5, 7.9	TN1000/15 Throttle handle in rear cockpit, Option	March 2008	17. April. 2008	
6	0.3, 0.5, 2.11, 7.24	Rudder pedals-loops (safety bows), manual revisions TN1000/16	May 2008	June 11. 2008	

Flight manual DG-1000T

0.1 Record of revisions continued

Rev. No.	Affected Pages/section	Description	Issue Date	EASA Approval Date	Inserted Date Signature
7	0.3, 0.6, 0.7, 9.1-9.12	Electrically operated main landing gear TN1000/14	Nov. 2008	28. January 2009	
8	0.6, 9.1, 9.2, 9.13	Special equipment for very small pilots TN1000/17	May 2010	20. July 2010	
9	0.2 - 06, 1.4, 2.6, 2.11, 2.12, 4.3, 4.5 - 4.7, 4.9, 4.10, 4.13, 4.14, 4.29, 6.3, 6.5, 6.6, 6.10, 6.11, 7.2, 7.9, 7.12, 7.18, 7.21, 7.23, 7.24, 9.7, 9.13	Manual revision TN1000/18	Febr. 2011	13.05.2011	

Flight manual DG-1000T

0.2 List of effective pages

Section	page	issued	replaced	replaced	replaced	replaced
0	0.0	July 2005				
	0.1	see manual amendments				
	0.2	"				
	0.3	"				
	0.4	"				
	0.5	"				
	0.6	"				
	0.7	July 2005				
1	1.1	"				
	1.2	"				
	1.3	"				
	1.4	"	Febr. 2011			
	1.5	"	Jan. 07			
	1.6	"	Jan. 07			
2	App. 2.1	July 2005				
	" 2.2	"				
	" 2.3	"				
	" 2.4	"				
	" 2.5	"	Jan. 07			
	" 2.6	"	Febr. 2011			
	" 2.7	"				
	" 2.8	"				
	" 2.9	"				
	" 2.10	"				
	" 2.11	"	Jan. 07	May 2008	Febr. 2011	
	" 2.12	"	Jan. 07	Oct. 07	Febr. 2011	
	2.13					
	2.14		Jan. 07			
	2.15		Jan. 07			
3	" 3.1	July 2005				
	" 3.2	"				
	" 3.3	"	Jan. 06			
	" 3.4	"				
	" 3.5	"				
	" 3.6	"				
	" 3.7	"				
	" 3.8	"				

Flight manual DG-1000T

0.2 List of effective pages (cont.)

Section	page	issued	replaced	replaced	replaced	replaced
4	App. 4.1	July 2005				
	" 4.2	"				
	" 4.3	"	Febr. 2011			
	" 4.4	"				
	" 4.5	"	Febr. 2011			
	" 4.6	"	Oct. 07	Febr. 2011		
	" 4.7	"	Febr. 2011			
	" 4.8	"				
	" 4.9	"	Febr. 08	Febr. 2011		
	" 4.10	"	Febr. 2011			
	" 4.11	"				
	" 4.12	"	Oct. 0707			
	" 4.13	"	Jan. 07	Oct. 07	Febr. 2011	
	" 4.14	"	Febr. 2011			
	" 4.15	"				
	" 4.16	"	Jan. 07			
	" 4.17	"	Jan. 07	Febr. 08		
	" 4.18	"	Jan. 07			
	" 4.19	"				
	" 4.20	"				
	" 4.21	"	Jan. 07			
	" 4.22	"				
	" 4.23	"				
	" 4.24	"	Jan. 07			
	" 4.25	"	Jan. 07			
	" 4.26	"				
	" 4.27	"				
	" 4.28	"				
	" 4.29	"	Febr. 2011			
5	" 5.1	July 2005				
	" 5.2	"	Febr. 2011			
	" 5.3	"	Jan. 07			
	" 5.4	"				
	App. 5.5	"	Jan. 07			
	" 5.6	"	Jan. 07			
	" 5.7	"	Jan. 07			
	" 5.8	"	Jan. 07			
	" 5.9	"				

Flight manual DG-1000T

0.2 List of effective pages (cont.)

Section	Page	issued	replaced	replaced	replaced	replaced
6	6.1	July 2005				
	6.2	"				
	6.3	"	Febr. 2011			
	6.4	"				
	6.5	"	Febr. 2011			
	6.6	"	Febr. 2011			
	6.7	"				
	6.8	"	Jan. 07			
	6.9	"				
	6.10	"	Febr. 2011			
	6.11	"	Febr. 2011			
7	7.1	July 2005				
	7.2	"	Febr. 2011			
	7.3	"				
	7.4	"				
	7.5	"	Febr. 08			
	7.6	"				
	7.7	"				
	7.8	"				
	7.9	"	March 08	Febr. 2011		
	7.10	"				
	7.11	"				
	7.12	"	Febr. 2011			
	7.13	"				
	7.14	"	Oct. 06	Oct. 07		
7.15	"	Oct. 06	Oct. 07			
7.16	"	Oct. 07				
7.17	"	Oct. 07				
7.18	"	Febr. 2011				
7.19	"					
7.20	"					
7.21	"	Febr. 2011				
7.22	"					
7.23	"					
7.24	"	May 2008	Febr. 2011			

Flight manual DG-1000T

0.2 List of effective pages (cont.)

Section	Page	issued	replaced	replaced	replaced	replaced
8	8.1	July 2005				
	8.2	"				
	8.3	"				
	8.4	"				
	8.5	"				
	8.6	"				
9	9.1	Nov. 2008	May 2010			
	9.2	"	May 2010			
	9.3	"				
	9.4	"				
	9.5	"				
	9.6	"				
	9.7	"	Febr. 2011			
	9.8	"				
	9.9	"				
	9.10	"				
	9.11	"				
	9.12	"				
	9.13	May 2010	Febr. 2011			

Flight manual DG-1000T

0.3 Table of contents

	Section
General (a non-approved section)	1
Limitations (an approved section)	2
Emergency procedures (an approved section)	3
Normal procedures (an approved section)	4
Performance (a partly approved section)	5
Mass (weight) and balance (a non-approved section)	6
Motorglider and systems description (a non-approved section)	7
Motorglider handling, care and maintenance (a non-approved section)	8
Supplements	9

Flight manual DG-1000T

1 General

Section	Page
1.1 Introduction.....	1.2
1.2 Certification basis	1.2
1.3 Warnings, cautions and notes	1.3
1.4 Descriptive data	1.4
1.5 Three view drawing	1.6

Flight manual DG-1000T

1.1 Introduction

The motorglider flight manual has been prepared to provide pilots and instructors with information for the safe and efficient operation of the DG-1000T glider.

This manual includes the material required to be furnished to the pilot by JAR Part 22. It also contains supplemental data supplied by the glider manufacturer.

1.2 Certification basis

This type of motorglider has been approved by the EASA in accordance with:

Airworthiness requirements:

JAR Part 22 „*Sailplanes and powered sailplanes*“, amendment 6, issued 1. August 2001.

The Type Certificate No. EASA.A.072 has been issued on January 27. 2006.

Category of Airworthiness: "Utility" or
„Aerobatic“ with 18m span without waterballast and
if the required equipment is installed.

Flight manual DG-1000T

1.3 Warnings, cautions and notes

The following definitions apply to warnings, cautions and notes used in the flight manual.

"Warning"

means that the non observation of the corresponding procedure leads to an immediate or important degradation of the flight safety.

"Caution"

means that the non observation of the corresponding procedure leads to a minor or to a more or less long term degradation of the flight safety.

"Note"

draws the attention on any special item not directly related to safety but which is important or unusual.

Flight manual DG-1000T

1.4 Descriptive data

The DG-1000T is a self-sustainer two-place high performance motorglider with retractable powerplant for training and cross country flying and in addition for aerobatic training.

The DG-1000T is available with different wing spans:

- A) Wing constructed from carbonfibre reinforced plastics with parting at y= 8,6m and wing tips for 20 m span with Winglets.
Wing tips for 18 m span are optional.
- B) Wing constructed from carbonfibre reinforced plastics with 18 m span without parting.
Parting at y= 8,6m is optional

- Automatic hook-ups for all controls.
- Comfortable seating and modern cockpit design similar to the DG-single-seaters - safety cockpit.
- Large 2 piece canopy for very good in-flight vision.
- Draught free canopy demist and 1 adjustable swivel air vent for each pilot.
- Sealed airbrake and landing gear boxes.
- Controls in each cockpit.
- All controls are operated with the left hand, which enables the right hand to remain on the control stick.

The DG-1000T is available with 3 different versions of the undercarriage:

- A) Very high spring mounted retractable main wheel with disc-brake, tail wheel.
- B) High spring mounted retractable main wheel with disc-brake, tail wheel and nose wheel
- C) Fixed spring mounted main wheel with disc-brake, tail wheel and nose wheel.

The main undercarriages versions B and C are interchangeable.

Other characteristics:

Waterballast in the wings and in the fin are optional with 18m span and standard with 20m span.

Standard: A ballast-box is installed in the fin. It can be used to compensate the mass of the rear pilot and as a trim-possibility for heavy pilots.

Max. ballast capacity: 12 kg.

Option: 2 ballast boxes in the front cockpit. The trim-weights used for the trim-ballast box in the fin also fit into these ballast boxes.

Flight manual DG-1000T

Powerplant and powerplant controls

- Retractable powerplant with air-cooled Solo 2350C two stroke engine and CFRP-Composite propeller DG-P001-1
- Electrical engine extension-retraction, operated automatically with the ignition switch or manually as back-up, electronic safety devices to avoid misoperation.
- Engine control instruments with digital LCD indication (Microprocessor technology) DEI-NT including stall warning, outside air thermometer, landing gear warning and canopy warning.

Technical data

Span	m / ft	18 / 59.1	20 / 55.62
Wing area	m ² / ft ²	16,72 / 180	17,53 / 189
Aspect ratio	/	19,38	22,82
Length	m / ft	8,57 / 28.12	
Fuselage height	m / ft	1,0 / 3.28	
Fuselage width	m / ft	0,73 / 2.4	
Span of the horizontal tailplane	m / ft	3,2 / 10.5	
Waterballast Wings	max. kg (l) / US.gal	160 / 42.3	160 / 42.3
Waterballast fin	max. kg (l) / US.gal	6,2 / 1.64	
Trim ballast fin	max. kg / lbs	12 / 26.5	
Empty mass with basic instruments*	kg / lbs	461 / 1016	465 / 1025
Wing loading (with one Pilot 80kg / 176 lbs)	kg/m ² / lbs/ft ²	32,4 / 6.64	31,1 / 6.37
max. take-off mass (max. TOW)	kg / lbs	750 / 1653	750 / 1653
max. wing loading	kg/m ² / lbs/ft ²	44,9 / 9.2	42,8 / 8.77
Aerobatics		unlimited	simple
		Category „A“	
max. TOW for aerobatics	kg / lbs	630 / 1389	/
max. speed	km/h / kts	270 / 146	270 / 146

Powerplant

engine	Solo 2350C two-cylinder-two-stroke-engine		
power	KW / hp	22 / 30	
Reduction gear		1:2,3	
Fuel tank capacity	Liter / US.gal	22 / 5.81	
Propeller	DG-P001-1	CFRP-Composite	
Propeller diameter	m / ft	1,48 / 4.86	

*Options will increase the empty mass accordingly!

1.5 three view drawing (dimensions in mm)

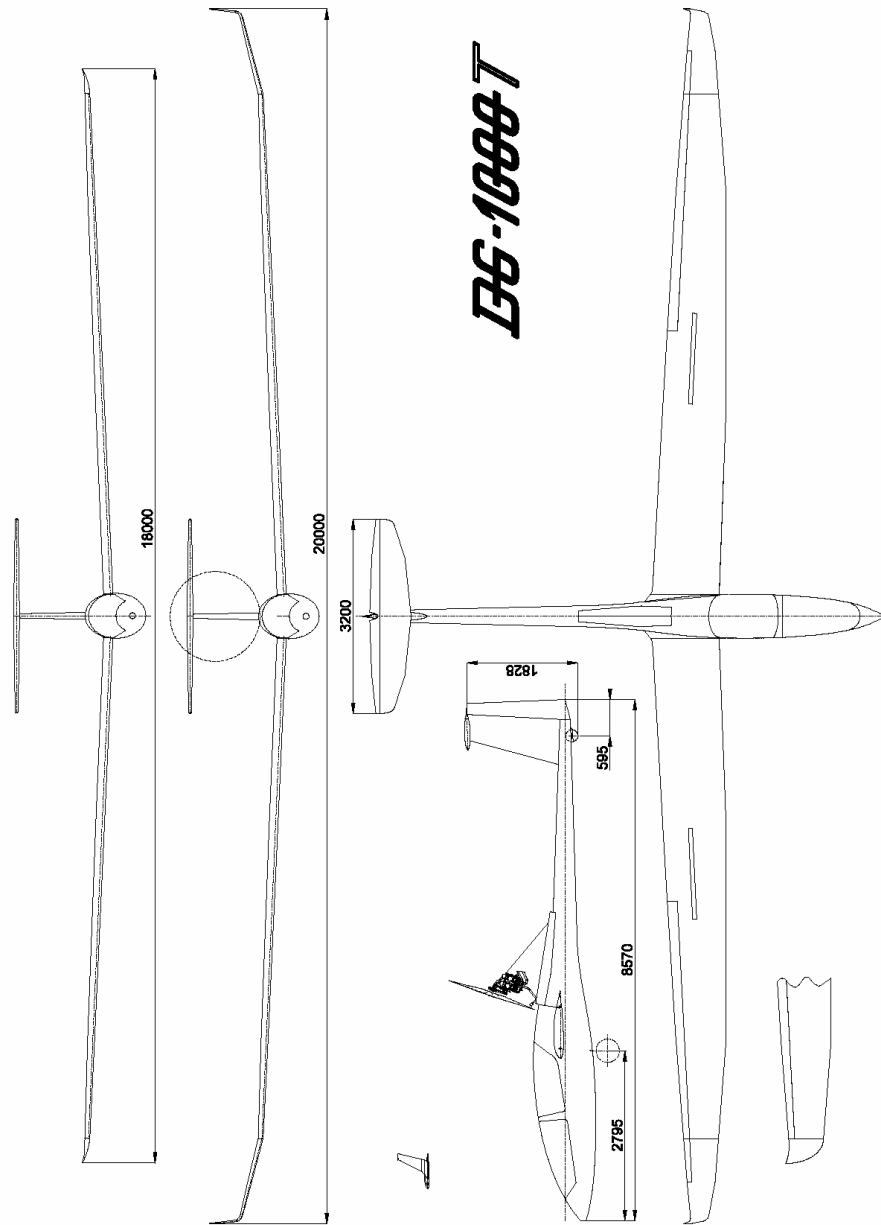

2 Limitations

Section	Page
2.1 Introduction.....	2.2
2.2 Airspeed	2.3
2.3 Airspeed Indicator Markings	2.4
2.4 Power plant	2.5
2.5 Power plant instrument markings (DEI-NT)	2.5
2.6 Fuel.....	2.6
2.7 Mass (weight).....	2.7
2.8 Centre of gravity	2.8
2.9 Approved manoeuvres	2.8
2.10 Manoeuvring load factors	2.9
2.11 Flight crew	2.9
2.12 Kinds of operation.....	2.10
2.13 Minimum equipment.....	2.11
2.14 Aerotow, winch and autotow launching	2.12
2.15 Crosswinds	2.12
2.16 Tyre Pressure	2.13
2.17 Waterballast (Option).....	2.13
2.18 Fin tank (Option).....	2.13
2.19 Trim ballast box in the fin.....	2.13
2.20 Other limitations	2.14
2.21 Limitations placards.....	2.15

Flight manual DG-1000T

2.1 Introduction

Section 2 includes operating limitations, instrument markings and basic placards necessary for safe operation of the glider, its standard systems and standard equipment.

The limitations included in this section have been approved by the EASA.

Flight manual DG-1000T

2.2 Airspeed

Airspeed limitations and their operational significance are shown below

	Speed	IAS km/h (kts.)	Remarks
VNE	Never exceed speed	270 (146)	Do not exceed this speed in any operation and do not use more than 1/3 of control deflection.
VPE	Max. speed with powerplant extended	185 (100)	Do not exceed this speed with the powerplant extended (engine idling)
VRA	Rough air speed	185 (100)	Do not exceed this speed except in smooth air and then only with caution. Rough air is in lee-wave rotors, thunderclouds, visible whirlwinds or over mountain crests etc.
VA	Manoeuvring speed	185 (100)	Do not make full or abrupt control movement above this speed, because under certain conditions the motorglider may be overstressed by full control movement.
VW	Maximum winch-launching speed	150 (81)	Do not exceed this speed during winch- or auto-tow-launching
VT	Maximum aero-towing speed	185 (100)	Do not exceed this speed during aerotowing.
VLO	Maximum landing gear operating speed	185 (100)	Do not extend or retract the landing gear above this speed.
VPO	Max. speed to extend and re-tract the power-plant	100 (54)	Do not extend or retract the powerplant above this speed

Warning: At higher altitudes the true airspeed is higher than the indicated airspeed, so V_{NE} is reduced with altitude according to the table below, see also section 4.5.8.

Altitude in [m]	0-3000	4000	5000	6000	7000	8000
V_{NE} indicated km/h	270	256	243	230	217	205

Altitude in [ft]	0-10000	13000	16000	20000	23000	26000
V_{NE} indicated kts.	146	138	131	124	117	111

Flight manual DG-1000T

2.3 Airspeed Indicator Markings

Airspeed indicator markings and their colour code significance are shown below.

Marking	(IAS) value or range km/h (kts)	Significance
Green Arc	88 – 185 (47.5 – 100)	Normal operating range (Lower limit is the speed $1,1 * V_{S1}$ with maximum mass and foremost C.G. Upper limit is the maximum rough air airspeed.)
Yellow Arc	185 – 270 (100 – 146)	Manoeuvres must be conducted with caution and only in smooth air.
Red Line	270 (146)	Maximum speed for all operations.
Blue line	90 (49)	Speed of best climb V_y
Yellow triangle	100 (54)	Approach speed at maximum weight without water ballast .

Flight manual DG-1000T

2.4 Power plant

Engine manufacturer: Solo Kleinmotoren
Sindelfingen/Maichingen
Germany

Engine model: Solo 2350C
2 cylinder air-cooled two stroke engine

Maximum power: Take off: 22 kW (30 hp)
continuous: 20 kW (27 hp)

Max. engine RPM: 6500 RPM
Max. continuous RPM: 6100 RPM

Max. cylinderhead temperature: 270°C (518°F)
With Poly-V belt reduction gear 1:2,3

Propeller: Diameter 1.48 m (4.86 ft)
Manufacturer: DG Flugzeugbau GmbH, Germany
Model: DG-P001-1

2.5 Power plant instrument markings (on DEI-NT, DEI=digital engine indicator)

Power plant instrument markings and their significance are shown below:

Engine speed indicator:

On centre of the DEI-NT display, indication digital with 4 digits, limitation data printed above display:

green	6100	max. continuous RPM
yellow	6100 – 6500	caution range
red	6500	max. RPM

Max. continuous RPM:

When exceeding this RPM a blinking “Hi” appears at the left hand side of the RPM.

Max. RPM:

When exceeding this RPM a full screen warning “Engine Speed” appears, when this warning has been confirmed (by pushing the selector knob at the right hand side of the display) the engine speed display is blinking whilst the engine speed is above max. RPM..

Flight manual DG-1000T

Cylinderhead temperature indicator (CHT):

On right hand upper side of the DEI-NT display, indication digital with 3 digits, limitation data printed above display:

red 270°C

When exceeding this temperature a full screen warning “CHT overTemp” appears, when this warning has been confirmed (by pushing the selector knob at the right hand side of the display) the CHT display will keep blinking as long as the CHT is above the max. CHT.

Fuel quantity indicator:

On left hand upper side of the DEI-NT display, indication digital with 2 digits. Limitation data for the non useable amount of fuel printed above the display:

red 0.5 l

When a fuel quantity of approx. 4 Litres is reached a full screen warning “Low Fuel” appears, when this warning has been confirmed (by pushing the selector knob at the right hand side of the display) “R” is displayed and blinking.

2.6 Fuel

Fuel capacity:

Fuselage tank:

total: 22 l (5.81 US gal.)

Non useable amount of fuel: 0.5 l (0.15 US gal.)

Useable amount of fuel: 21,5 l (5.68 US gal)

Approved fuel grades:

- Car super gasoline min. 95 octane (ROZ) (RON) leaded or unleaded
- or: AVGAS 100 LL (only if super gasoline is not available)
- or: mix 50% AVGAS 100 LL and 50% Car super gasoline unleaded min. 92 octane (ROZ) (RON)

mixed with self mixing Super quality two stroke oil - specification TSC 3 or API TC or JASO FC or higher quality. Mixing ratio 1:50.

Note: The SOLO company recommends the following oil types: CASTROL Actevo 2T or CASTROL Super Two stroke.

Flight manual DG-1000T

2.7 Mass (weight)

Category A „Aerobatic“

Maximum take-off and landing mass: 630 kg 1389 lbs.

Category „Utility“:

with waterballast:

Maximum take and landing off mass: 750 kg 1653 lbs.

without waterballast: Maximum take-off and landing mass = $W_{NLP} + W_{wings}$

W_{NLP} = Maximum mass of the non lifting parts (see below)

W_{wings} = actual mass of the wings

Maximum mass of the non lifting parts = 554 kg 1221 lbs.

Caution: It is recommended to dump the waterballast before landing on airfields. Always dump the ballast before an outlanding.

Maximum mass in baggage compartment: 15 kg 33 lbs.

Caution: Heavy pieces of baggage must be secured to the baggage compartment floor (screwing to the floor or with belts). The max. mass secured on one half of the floor (left and right of fuselage centre line) should not exceed 7,5kg (16.5 lbs.).

Ballast

1. Maximum waterballast

in the wings: 160 kg 353 lbs.

in the fin 6,2 kg 13.7 lbs.

2. Maximum mass in the trim-ballast box in the fin: 12 kg 26.5 lbs.

The max. take-off mass is not to be exceeded with 1. and 2. together.

Warning: Follow the loading procedures see section 6.

Flight manual DG-1000T

2.8 Centre of gravity

Centre of gravity range in flight is
200mm (7.87 inch) up to 440mm (17.32 inch) behind datum.

Datum = wing leading edge at the root rib.
Horizontal reference line = aft fuselage centre line horizontal.

C.G. diagrams and loading chart see sect. 6.

2.9 Approved manoeuvres

Category „Utility“:

The glider is certified for normal gliding in the "Utility" category.
Simple aerobatics are approved but only without waterballast and with the weight of the rear pilot compensated by ballast in the ballast box in the fin see section 6.8.7.

The following aerobatic manoeuvres are approved with all spans:

Spins	Chandelle
Inside loop	Turn
Lazy Eight	

Recommended entry speeds see section 4.5.11.1.

Category „Aerobatic“

Span 18 m without waterballast, max. mass 630 kg (1389 lbs.) and with the required equipment see section 2.13 installed and with the weight of the rear pilot compensated by ballast in the ballast box in the fin see section 6.8.7.

In addition to the manoeuvres in category „Utility“ the following manoeuvres are approved:

Inverted flight	half flick roll from normal to inverted flight with half loop
half loop and half roll	half flick roll from inverted to normal flight
half roll and half loop	
slow roll	

Recommended entry speeds see section 4.5.11.2.

Flight manual DG-1000T

2.10 Manoeuvring load factors

The following load factors must not be exceeded:

Category		Utility	Aerobatic
at manoeuvring speed	V _A	+5,3 -2,65	+7,0 -5,0
at max. speed	V _{NE}	+4,0 -1,5	+7,0 -5,0
with airbrakes extended	V _{NE}	+3,5 0	+3,5 0

2.11 Flight crew

- a) single seated, only permissible in the front seat
max. load in the front seat 110 kg (242 lbs.)
min. load in the front seat see placard in cockpit
and weighing
report page 6.7
- b) two seated
Either the front seat or the rear seat may designated as seat of the pilot in command.
If the rear seat is to be designated it must be assured that all necessary operating items and instruments are installed and that the pilot in command has sufficient training in flying safely from the rear seat.
max. cockpit load is 210 kg (463 lbs.) with a max. of 105 kg (231 lbs.) in the front seat or 110 kg (242 lbs.) in the front seat and 90 kg (198 lbs.) in the rear seat.
min. cockpit load in the front seat is the min. cockpit load see a) minus 40% of the load in the rear seat. This means that 10 kg (22 lbs.) in the rear seat replaces 4 kg (8.8 lbs.) missing cockpit load in the front seat.

With these loads, the C.G. range given under 6.8 will be kept in the limits if the empty weight C.G. is in its limits. See loading chart in sect. 6.8.

Caution:

With lower pilot weights lead ballast must be added to the seat.

Ballast put on the seat (lead ballast cushion) must be fastened at the safety belt anchor point.

Option: Provision for removable trim-ballast in the front cockpit see sect 7.17.1.

Note: For Australia the lower limit for the min. load in the cockpit should not exceed 66 kg (146 lbs.). A provision for removable ballast see sect. 7.17.1 is mandatory.

Flight manual DG-1000T

2.12 Kinds of operation

A) All configurations

Flights according to VFR (daylight)

Aerotow

Winch- and auto-launching

B) In addition when flying without waterballast

1. Cloud flying (daylight): permitted when properly instrumented (see section 2.13).
2. Simple aerobatics see sect. 4.5.11.1. Category „Utility“
3. Aerobatics see section 4.5.11.2. Category „Aerobatic“ if the required equipment (see section 2.13 b)) is installed, only with 18 m span.

Note: Cloud flying is not permitted in the USA, Canada and Australia.

Flight manual DG-1000T

2.13 Minimum equipment

As minimum equipment only the instruments and equipment specified in the equipment list (see maintenance manual) are admissible.

Note: The actual equipment list is filed in the enclosures of the maintenance manual.

a) Normal operation

Airspeed indicator Range: 0-300 km/h (0-165kts.);

Speed range markings see sect. 2.3

Altimeter Range: 0 – min. 10.000 m,

Altimeter with fine range pointer, 1 turn max. 1000 m (3000 ft.)

Magnetic compass (compensated in the aircraft)

Four piece symmetrical safety harness

VHF - transceiver (ready for operation)

Engine speed indicator, Fuel quantity indicator, Cylinder head temperature indicator, Engine elapsed time indicator (counts as long as the engine is running):

These 4 indicators are incorporated in the DEI-NT. Markings and display of the limitations see sect.2.5

Outside air temperature gauge: with probe in the fuselage nose, also incorporated in the DEI-NT.

Rear view mirror

Safety bow 10L35/1 in the fin battery box if no battery is installed.

(description see section 4.2.5).

Parachute automatic or manual type or a suitable firm back cushion approximately 8 cm (3 in.) thick for the front seat and 3 – 8 cm (1 – 3 in.) thick for the rear seat

Required placards, check lists

Flight and maintenance manual.

b) In addition for cloud flying

(Not permitted in Canada and Australia)

Variometer

Turn and bank indicator

c) In addition for aerobatics (Category Aerobatic)

Accelerometer capable of retaining max. and min. g-values with markings red radial lines at +7 g and -5 g.

Note: Experience has shown that the installed airspeed indicator system may be used for cloud flying.

Flight manual DG-1000T

2.14 Aerotow, winch and autotow launching

2.14.1 Weak links in towing cables

	Winch launching	aerotow
max.	11000 N (2425 lbs.)	11000 N (2425 lbs.)
recommended	10000 N ± 1000 N (2200 lbs. ± 220 lbs.)	10000 N ± 1000 N (2200 lbs. ± 220 lbs.) for tow behind aeroplanes 6000 N ± 600 N (1323 lbs. ± 132 lbs.) for tow behind slow tow planes eg. Ultralight planes or touring motorgliders

2.14.2 Towing cables (for aerotow only)

Length: 40-70 m (130 - 230 ft)

Material: hemp- or plastic fibres

2.14.3 Max. towing speeds

		maximum	maximum
Aerotow	$V_T =$	185km/h	100 kts.
Winch- and autotow	$V_W =$	150 km/h	81 kts.

2.14.4 Tow Release

The C.G. tow release (installed in front of the main wheel) is suitable only for winch- and auto launching.

The nose hook is to be used only for aerotow.

2.15 Crosswinds

The demonstrated crosswind velocity is 15 km/h (8 kts.) according to the airworthiness requirements.

Flight manual DG-1000T

2.16 Tyre Pressure

Main wheel	2,5 bar	(36 psi)
Nose wheel (if installed)	2,5 bar	(36 psi)
Tail wheel	4,0 bar	(58 psi)

2.17 Waterballast (Option)

Max. capacity 80 l (21.1 U.S. gal) per wing.

Filling the water ballast is only allowed with a filling system which enables determination of the exact amount of ballast filled, e.g. water gauge or calibrated canisters. Only symmetrical loading is allowed.

After filling, balance the wings by dumping enough water from the heavy wing, see 4.2.2.

Flight with leaking watertanks is prohibited, as this may result in asymmetrical loading condition.

Warning: Follow the loading chart, see section 6.8.

The max. take-off weight must not be exceeded.

2.18 Fin tank (Option)

Warning: As it is dangerous to fly with empty wing tanks while ballast is resting in the fin, **it is prohibited to fill water into the fin tank if there is any risk of icing.** The flight conditions must comply with the following table:

min. ground temperature	°C	13,5	17	24	31	38
	°F	56	63	75	88	100
max. flight altitude	m	1500	2000	3000	4000	5000
	ft	5000	6500	10000	13000	16500

In addition the outside air temperature OAT gauge is to be monitored.

The OAT should not be lower than 2°C (36°F)!

2.19 Trim ballast box in the fin

A box for ballast (trim-weights) is installed in the fin. It can be used to compensate the mass of the rear pilot and as a trim-possibility for heavy pilots.

Warning: Follow the loading chart see 6.8.7.

Tape the cover of the fin ballast box with tape min. 19mm (3/4 in.) wide prior to each flight.

2.20 Other limitations

Approach and landing

Landing with the engine extended and running is prohibited, except in an emergency.

Always land in the gliding configuration, engine retracted.

2.20.1 Warning: Self-launching is not permitted

2.21 Limitations placards

DG Flugzeugbau GmbH
 Type: DG – 1000T Serial No.: 10- T
 Year of construction:

Maximum airspeeds	km/h	kts.
Winch launching	150	81
Aero-tow	185	100
Manoeuvring V _A	185	100
Rough air	185	100
Maximum speed V _{NE}	270	146
Powerplant extended	185	100
Powerplant extension-retraction	100	54

Approved aerobatic manoeuvres, only without waterballast:
 Pos. Loop, Chandelle, Spin, Stall turn
 In addition Category A:
 Only with 18 m span without waterballast, engine retracted or removed:
Half loop and half roll, half roll and half loop, slow roll, inverted flight, half positive flick roll from normal flight with half loop, half negative flick roll from inverted flight
 Maximum mass:

Category A	630 kg	1389 lbs.
Category U	750 kg	1653 lbs.
Category U without waterballast	kg	lbs.

Other cockpit placards see section 7

**Gepäck max. 15 kg
 baggage max. 33 lbs.**

**Soilbruchstelle 10000 N
 rated load 2200 lbs.**

**Reifendruck 4 bar
 Tyre pressure 58 psi**

Tail wheel

**Reifendruck 2,5 bar
 Tyre pressure 36 psi**

Main wheel

**Reifendruck 2,5 bar
 Tyre pressure 36 psi**

Nose wheel (if installed)

Loading chart

Cockpit load maximum	front seat		rear seat (Parachute included)	
	110 kg	242 lbs.	90 kg	198 lbs.
or maximum	105 kg	231 lbs.	105 kg	231 lbs.
minimum	kg	lbs.	/	/
minimum	kg	lbs.	/	/

Without fin battery
 With fin battery
 With lower pilot weight necessary ballast must be added.

- Cockpit Check**
1. Lead ballast (for under weight pilot)?
 2. Parachute worn properly?
 3. Safety harness buckled?
 4. Front seat: pedals adjusted?
 Rear seat: seating height adjusted?
 5. All controls and knobs in reach?
 6. Altimeter?
 7. Dive brakes cycled and locked?
 8. Positive control check ? (One person at the control surfaces).
 9. Fin ballast tank emptied or correct amount filled in?
 10. Trim ballast box in the fin, correct amount filled in?
 Locking device completely engaged?
 11. Battery in the fin? Loading chart regarded?
 12. Trim?
 13. Fuel level?
 14. Fuel cock open?
 15. Both canopies locked?
 16. Runway free?

limits for use of the waterballast tank

minimum ground temperature	°C	13.5	17	24	31	38
	°F	56	63	75	88	100
maximum flight altitude above GND	m	1500	2000	3000	4000	5000
	ft.	5000	6500	10000	13000	16500

Altitude in [m]	0-3000	4000	5000	6000	7000	8000
V _{NE} IAS km/h	270	256	243	230	217	205
Altitude in [ft]	0-10000	13000	16000	20000	23000	26000
V _{NE} IAS kts.	146	138	131	124	117	111

Ballast box in the fin
 Min. load in the front seat

kg	○	kg
box empty		box filled

At the control-light in the front instrument panel

Warning:
 Rigging of the horizontal tailplane is only permitted with nose down trim-setting!

at the upper left hand side of the fin

3 Emergency procedures

Section	Page
3.1 Introduction.....	3.2
3.2 Canopy jettison	3.2
3.3 Bailing out.....	3.2
3.4 Stall recovery	3.2
3.5 Spin Recovery.....	3.3
3.6 Spiral dive recovery	3.3
3.7 Recovery from unintentional cloud flying.....	3.3
3.8 Flight with asymmetric waterballast.....	3.4
3.9 Defective fin ballast dump.....	3.4
3.10 Emergency wheel up landing.....	3.4
3.11 Emergency ground loop.....	3.5
3.12 Emergency landing on water	3.5
3.13 Power loss during flight.....	3.5
3.14 Fires.....	3.6
3.15 Loss of electrical power in flight.....	3.7
3.16 Starting the engine with the starter not working:.....	3.7
3.17 Retraction or extension of the power plant with the normal mechanism not working.....	3.7
3.18 Landing with the engine extended and stopped.....	3.8

3.1 Introduction

Section 3 provides a checklist and amplification for coping with emergencies that may occur. Emergency situations can be minimized by proper pre-flight inspections and maintenance.

Caution: Canopy jettison and bailing out should be practised several times on the ground before flying the aircraft.

3.2 Canopy jettison

To bail out the white-red canopy opening handle (left) has to be operated with your right hand. Open the canopy as far as possible.

If the canopy doesn't stay open (or is not blown away by the oncoming air), but is closed by the air pressure, you have to release the canopy in it's closed position by operating the red emergency release handle (right) with your left hand, then push the canopy upwards.

The retaining lines will tear off.

The gas struts (if installed) will disengage automatically

Warning: If bailing out with the engine running it is necessary to switch off the ignition and retract the engine with the manual switch even with the propeller still turning. The propeller will be stopped by the engine doors. Don't try to stop the propeller vertical and to retract the engine using the normal method.

3.3 Bailing out

First jettison both canopies, then open the safety harness and bail out. The low walls of the front cockpit allow for a quick push-off exit.

3.4 Stall recovery

Easing the stick forward and picking up a dropping wing with sufficient opposite rudder the glider can be recovered from the stall.

To recognize and prevent the stall, please refer to section 4.5.2.

3.5 Spin Recovery

Apply full opposite rudder against direction of the spin, pause.

Then ease stick forward until the rotation ceases, centralize the controls and carefully pull out of the dive.

The ailerons should be kept neutral during recovery.

Caution: To prevent unintentional spinning do not stall the motorglider. Fly with enough speed reserve especially in gusty conditions and in the landing pattern.

Intentional spins with waterballast are not permitted.

Height loss during recovery	ca. 50-100 m (160-320ft)
max. speed during recovery	max. 200 km/h (108 kts.)

3.6 Spiral dive recovery

Apply rudder and aileron in opposite direction and carefully pull out of the dive.

Spiral dive occurs only when spinning more than 2 turns with medium C.G. positions, see section 4.5.11.

To prevent spiral dives intentional spinning should only be executed at aft C.G. positions.

Recovery from unintentional spinning should be done immediately.

3.7 Recovery from unintentional cloud flying

Spins are not to be used to reduce altitude. In an emergency, pull out the dive brakes fully before exceeding a speed of 200 km/h and fly with max. 200 km/h (108 kts.) until leaving the cloud.

At higher speeds up to V_{NE} pull out the dive brakes very carefully because of high aerodynamic and g-loads.

3.8 Flight with asymmetric waterballast

If you suspect that the waterballast does not dump symmetrically you have to close the dump valves of the wingtanks immediately, to avoid greater asymmetry.

Asymmetry can be verified by the necessary aileron deflection in straight flight at low airspeeds.

When flying with asymmetric waterballast you have to increase the airspeed, especially in turns, so that you can avoid a stall at all costs.

Fly the landing pattern and touch down approx. 10 km/h (6 kts.) faster than usual and after touch down control carefully the bank angle to avoid the wing touching the ground too early.

3.9 Defective fin ballast dump

If suddenly the operating force of the fin ballast control handle is uncommonly low (you don't feel the force of the retaining spring) you must suspect that the valve will not be opened. In this case it is prohibited to dump the wing ballast to avoid an inadmissible aft C.G. position.

You must perform the landing with full ballast, try to avoid an outlanding.

3.10 Emergency wheel up landing

It is not recommended to execute a wheel up emergency landing, as the energy absorption capability of the fuselage is much smaller than that of the landing gear.

If the landing gear can't be extended touch down with small angle of attack.

Flight manual DG-1000T

3.11 Emergency ground loop

If there is the risk of overshooting the landing strip you have to decide at least 40 m (130 ft) before the end of the field to execute a controlled ground loop:

- If possible turn into the wind!
- At the same time try to lift the tail by pushing the stick forward.

3.12 Emergency landing on water

From the experience with emergency water landing we know that it is likely that the motorglider will dive into the water, cockpit first.

Therefore an emergency landing on water should be the last choice.
In the case of a water landing, however, extend the landing gear.

Recommended procedures :

On downwind leg of the landing pattern: Extend the landing gear, unlock the parachute harness (not the seat harness)

Touch down: With landing gear extended and airspeed as low as possible.

At point of touch-down: Use your left arm to protect your face against possible canopy fracture.

After touch down: Unfasten seat belt harnesses and undo parachute.

Leaving the cockpit under water: If the canopy has not fractured, opening the canopy may be possible only after the forward fuselage is almost completely filled with water.

3.13 Power loss during flight

Push the control stick forward immediately, watch the airspeed indicator!

Check:

- fuel cock position?
- fuel quantity?

If no change, retract the engine or land with extended engine.

- engine extended increases the sink rate to approx. 1.1 m/s (220 ft/min.) at 90 km/h (49 kts) or 1.3 m/s (260 ft/min) at 100 km/h (54 kts).

Flight manual DG-1000T

3.14 Fires

3.9.1 In engine on the ground

- close fuel cock and switch off ignition if the engine is still running
- keep engine extended
- switch off main switch
- use extinguisher, cloth or suitable external means

3.9.2 In engine in flight

- close fuel cock
- switch off main switch
- open throttle fully if engine is still running until engine stops
- keep engine extended
- land as soon as possible
- extinguish fire

3.9.3 In the fuselage

3.9.3.1 Front fuselage (electrical fire)

- switch off main switch
- close ventilation, open swivel air vents and side window
- land as soon as possible if the fire is not extinguished (circuits are effectively protected by circuit breakers)

3.9.3.2 Rear fuselage (engine)

- close fuel cock
- open throttle fully if engine is still running until the engine stops
- keep engine extended or extend the engine
- switch off main switch
- if smoke prevents flying open ventilation
- land as soon as possible
- extinguish fire

3.15 Loss of electrical power in flight

- 3.11.1 With the engine retracted:
Continue flying as a sailplane.
- 3.11.2 With the engine extended not running:
Look for a landing field to do a safe outlanding.
- 3.11.3 With the engine extended and running:
Don't stop the engine. Fly to the next airfield and land.
The mechanical fuel pump allows engine operation without battery power.
Avoid longer sinking flights with the engine idling as lubrication of the engine will be insufficient.
Therefore stop the engine for the landing or apply some throttle at least every 60 seconds to supply oil to the engine.
Landing with the engine extended see sect. 3.18.

3.16 Starting the engine with the starter not working:

In flight:

Dive starting the engine is not possible as within the certified speed range (max. 185 km/h, 100 kts with engine extended) the engine speed due to windmilling is not high enough to start the engine..

On the ground:

Handstarting the engine is not possible as you can't reach the necessary starting RPM.

3.17 Retraction or extension of the power plant with the normal mechanism not working

Extend or retract the power plant via the manual switch on the instrument panel. This procedure is only to be followed in an emergency as all safety devices (e.g. against retraction of the engine while running) are by-passed.

3.18 Landing with the engine extended and stopped

Landing with the engine extended and stopped is not a potential risk. However due to the drag from the extended engine, the approach should be made not using airbrakes fully extended.
Fully extended airbrakes may result in a heavy and uncomfortable landing. It is recommended to approach somewhat faster than usual.

4 Normal procedures

Section	Page
4.1 Introduction.....	4.2
4.2 Rigging and derigging, filling the watertanks	4.2
4.2.1 Rigging.....	4.2
4.2.2 Filling the wing water ballast tanks	4.4
4.2.3 Filling the fin ballast tank	4.5
4.2.4 Ballast box in the fin	4.5
4.2.5 Installation of a battery in the fin	4.6
4.2.6 Refuelling.....	4.6
4.2.7 Derigging	4.6
4.3 Daily Inspection	4.7
4.4 Pre-flight inspection.....	4.11
4.5 Normal procedures and recommended speeds	4.12
4.5.1 Launch.....	4.12
4.5.2 Free flight.....	4.13
4.5.3 Cruise engine on.....	4.14
4.5.4 Powerplant extension-retraction in flight	4.14
4.5.5 Approach and landing	4.17
4.5.6 Engine retraction on the ground.....	4.18
4.5.7 Flight with water ballast.....	4.18
4.5.8 Flight at high altitude and at low temperatures	4.20
4.5.9 Flight in rain and thunderstorms	4.21
4.5.10 Cloud flying	4.21
4.5.11 Aerobatics	4.22
4.6 Flight with the engine removed from the aircraft.....	4.29

4.1 Introduction

This section provides checklist and amplification procedures for the conduct of normal operation. Normal procedures associated with optional systems can be found in section 9.

4.2 Rigging and derigging, filling the watertanks

4.2.1 Rigging

1. Open the rear canopy.
2. Clean and lube the pins, bushings and the control connections.
3. Rigging the inboard wing panels
 All controls hook-up automatically. Therefore set the airbrake handle to the forward stop.
 Ailerons should be held neutral for rigging, airbrakes must be locked.
 Screw one of the rear wing securing pins on the tool W 38/2.
 Close both canopies. Push the right wing panel into place. Insert the rear securing pin with the tool at the rear attachment fitting. Push in the tool so far that the upper surface of the brass part of the tool is flush with the wing surface. Screw off the tool. Check if the locking device for the securing pin has engaged.
Note: If the wing refuses to slip close to the fuselage, you may try to insert the rigging pin W58 instead of the locking pin and try to move the wing towards the fuselage with help of the conical shape of this pin.
 Screw the other securing pin onto the tool.
 Open the rear canopy. Push in the left wing. Mount and check the left securing pin by the same method as the right side.
 Push the two main pins in as far as possible.
 Turn the handles up to the fuselage wall, while pulling out the white securing knob, then release the knob back to its locked position.

4. Rigging of the stabilizer

Battery box in the fin: Check if the securing wire 10L35 (made from piano wire) is installed. If a battery is to be installed refer to section 4.2.5, connect the battery.

Caution: Rigging of the horizontal tailplane is only permitted with **nose down** trim-setting. Therefore operate the trim release lever and push the control stick forward, then release the lever to engage the trim (don't operate the trim control knob, the trim should not be pushed to the most nose down position).

Screw the tool W 38/2 into the securing plate (near the top of the left surface of the fin). Pull out the securing plate with the tool, move it downwards to engage in the rigging position. Set the stabilizer on, so that the roller at the fuselage side push rod is inserted into the funnel at the elevator.

Watch carefully the procedure!

When the stabilizer is set down and laying on the fin, push it aft. The roller will engage and slide forward in the funnel if you hold the elevator in the pertinent position.

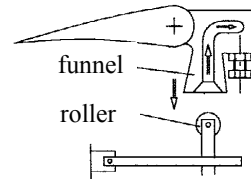

Release the securing device by pulling out with the tool and engage the securing device by lifting the tool. The securing plate must be flush with the surface of the fin. Screw out the tool.

Check for correct elevator connection by looking from the rear into the gap at the right hand side of the rudder.

5. Rigging of the outboard wing panels (20m wing extensions or 18 m wing tips): Insert the wing tip extensions into the wing. Press in the locking pin with your finger. Insert the wing tip until the aileron connector starts to slide onto the aileron. Strike firmly with the palm of your hand on to the wing tip to lock in the wing tip extension.
6. Tape the gaps of the wing-fuselage junctions and the wing joints.
7. Execute a positive control check, one helper to hold firmly the control surfaces is needed.

4.2.2 Filling the wing water ballast tanks

First open the fin tank and then open the right wing tank valve (top handle). Place the right wing tip on the ground. Attach the hose in the water outlet on the lower surface of the wing. Fill with water. Close the valve.

Place the left wing tip to the ground and fill the left tank accordingly. Filling with water ballast is only allowed with a filling system which enables you to determine the exact amount of ballast filled in, e.g. water gauge or calibrated canisters.

Warning: Fill the hose from your water containers but never from a main pressure water supply. Filling the wing tanks with excessive pressure (more than 0.2 bar, 3 psi) will definitely burst the wing shell!

Caution: If the tanks are to be filled up completely you must suck the air out of the tanks with the filling hose, as the tanks have no ventilation line.

Fill with the desired amount of water regarding the loading chart see section 6.8.5.

In case a valve leaks slightly, you may try to pull out the PVC pushrod of the valve to stop the leak. If this cannot be done successfully refer to maintenance manual 1.8.1. and 4.1.

It is not allowed to fly with leaking watertanks, as this may result in asymmetrical loading condition.

After filling the tanks, check to see if the wings are balanced. If one wing is heavier, dump enough water to balance the wings.

Finally press the Teflon-glass-fabric which shall close the dump holes against the wing-shell. There must always be a small amount of grease on the shell, to ensure that the covers stick to the shell.

Warning: Follow the loading chart section 6.8 must be observed. The maximum take-off weight must not be exceeded.

4.2.3 Filling the fin ballast tank

This tank must be filled after filling the wingtanks. Determine the amount (see section 6.8.6). Connect the transparent funnel equipped filling hose (supplied with the aircraft) via the hose connector GRS 10-12 to the hose which comes out of the left rear end of the fuselage.

The funnel can be suspended from the top of the rudder.

Fill with clean water using a graduated measuring vessel.

In addition you may check the content level by holding the filling hose against the scale on the fin.

After filling, push the fin tank dump lever in a forward direction (the dump valve will be closed by a spring).

Then remove the filling hose with the hose connector.

4.2.4 Ballast box in the fin

To fill the ballast box remove the Plexiglas cover plate by inserting a 6mm pin into the hole of the upper locking device and move the locking pin downwards. Determine the amount of trim-weights according to section 6.8.7. Slide the weights into the rails of the box. The heavy weights with 2,4 kg (5.3 lbs.) each must be installed in the lower 4 sections and the lighter weights with 1,2 kg (2.65 lbs.) each in the upper 2 sections. It doesn't matter in which sections the weights are installed (in case that not all sections will be filled up), but it is not allowed to insert the light weights into the sections for the heavy weights. Close the compartment.

Caution: When changing trim ballast, check condition and correct gluing of the foam rubber rings 10L45/2 in the ballast box in the fin. Without these rings a correct indication is not possible.

Replace damaged rings according to Service Info 67-07, attached to the MM.

Warning: Check that the locking device has engaged completely.

Tape the cover of the fin ballast box with tape min. 19mm (3/4 in.) wide prior to each flight.

A control light in the front instrument panel starts blinking after each transaction with the weights. By counting the amount of blinks, the amount of ballast can be determined. For a heavy weight 2 blinks appear and 1 blink for a light weight, this means 10 blinks if the box is filled up completely. After a pause of 2-3 seconds the blinking will be repeated etc. The blinking can be stopped by pressing on the control light. Pressing again on the control light reactivates the blinking feature.

After filling the ballast box you should check the correct indication of the control light.

A switch will be operated by the locking pin of the ballast box cover when the pin locks correctly. As long as the switch is not closed, the control light for the ballast box will blink with doubled speed without interruption. The blinking can't be switched off by pressing on the control light contrary to the blinking which indicates the amount of ballast.

Installation of a battery in the fin

A battery in the fin may be installed optionally.

To accomplish the installation the locking bow (part 10L35 made from piano wire) must be removed. The locking bow prevents the installation of a battery and serves as indicator if a battery is installed, as its ends are visible from the outside.

After removing the battery reinstall the locking bow.

Warning: The fin battery raises the min. cockpit load see section 6.8.4.

Only the use of the factory supplied battery Z110 (mass 5.5 kg, 12.1 lbs.) is permitted. Don't put any other objects in the battery box.

Refuelling

Fuel is transferred via a permanently installed refuelling pump from a can where the correct amount of oil is added and mixed prior to filling.

Oil: Use only super two stroke oil according to section 2.6

Switch on the main switch of the aircraft and extend the engine.

Couple the fuel filler hose to the fuselage side coupling (in left hand front side of the engine compartment).

Start the pump by pressing the push button located next to the coupling. As soon as the fuselage tank is full a built in device automatically switches off the pump. If you want to interrupt or to stop the filling procedure before the tank is full press again the push button.

Starting the pumping again is possible by pressing the push button again.

Warning: Make sure to fill in clean fuel without any water.

4.2.5 Derigging

Derigging follows the reverse of rigging.

Waterballast must be dumped first.

Lock the airbrakes.

For disassembling the securing pins of the wings the tool W 38/2 must be screwed into the thread completely.

The brass part of the tool will then disengage the securing of this bolt.

It is recommended to leave the securing pin in the right wing while you derig the left wing.

Derigging of the outboard wing panels (20m wing extensions or 18 m wing tips):

Use a 6 mm diameter pin for pressing in the locking pin on the wing's upper surface. Pull out the wing tip or the wing tip extension.

4.3 Daily Inspection

Please bear in mind the importance of the inspection after rigging the glider and respectively each day prior to the first take off. It is for your safety.

Caution: After a heavy landing or if other high loads have been imposed on your motorglider, you must execute a complete inspection referring to maintenance manual sect. 2.3 prior to the next take off. If you detect any damage, don't operate your aircraft before the damage is repaired. If the maintenance and repair manuals don't give adequate information, please contact the manufacturer.

A Inspection prior to rigging:

1. Wing roots and spar ends:-
 - a) check for cracks, delamination etc.;
 - b) check the bushes and their glued connection in root ribs and the spar ends for wear;
 - c) check the control hook-ups at the rootrib for wear and corrosion;
 - d) check the strings which hold the waterbags for sufficient tension (see maintenance manual sect. 4.1)
2. Fuselage at wing connection:-
 - a) check the lift pins for wear and corrosion;
 - b) check the control hook-up s including the water dump system for wear and corrosion.
3. Top of the vertical fin:-
 - a) check the mounting points of the horizontal tailplane and the elevator control hook-up for wear and corrosion
4. Check if the securing wire see section 4.2.5 is installed or if a fin battery (Option) is installed and connected
5. Horizontal tailplane:-
 - check the mounting points and the elevator control hook-up for wear and corrosion;
6. Rigging points for the outboard wing panels:-
 - check the lift pins and bushes for wear and corrosion and check their glued connections. Check the locking device for function and sufficient spring force.

B Inspection after rigging - Walk around the aircraft

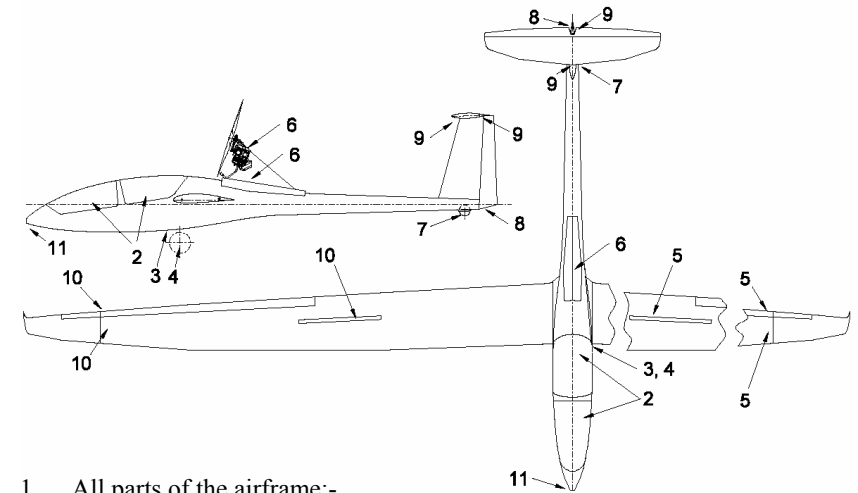

1. All parts of the airframe:-
 - a) check for flaws such as bubbles, holes, bumps and cracks in the surface;
 - b) check leading and trailing edges of the wings and control surfaces for cracks;
2. Cockpit area:-
 - a) check the canopy locking mechanism;
 - b) check the canopy emergency release see section 7.16 (not each day, but min. every 3 month);
 - c) check the main pin securing;
 - d) check all controls for wear and function, incl. positive control check;
 - e) check the tow release system for wear and function incl. cable release check;
 - f) check for foreign objects;
 - g) check the instrumentation for wear and function;
 - h) Switch on main switch, check the radio and other parts of the electric system (fuses!) for function;
 - i) check the engine controls
 - j) check all fuses
 - k) check the extension-retraction mechanism by operating it in both directions. The extension time should not exceed 13 seconds!
 - l) extend the engine
 - m) check the fuel filter for dirt or sludge, the filter is located in the baggage compartment.
 - n) check the fuel level by looking at the DEI and directly at the tank;
 - o) check if the fin tank is empty

Flight manual DG-1000T

3. C.G. Tow hook:-
 - a) check the ring muzzle of the C.G. hook for wear and function;
 - b) check for cleanliness and corrosion;
4. Main landing gear and nose wheel (if fitted):-
 - a) check the struts, the gear box, the gear doors and the tyre for wear; dirt in the struts can hinder the landing gear from locking over centre the next time!;
With TN1000/13 executed, standard from ser. no. 10-133 on:
Check all parts of the landing gear positive locking device (notch and latch at the landing gear struts) for dirt. Check the Bowden cable for damage.
 - b) check the tyre pressure;
main wheel: 2.5 bar - 36 psi
nose wheel: 2.5 bar - 36 psi
 - c) check wheel brake and hose for wear and function;
5. Left wing:-
 - a) check locking of the outboard wing;
 - b) check the aileron for excessive free play;
 - c) check airbrake- and box and control rod for wear and free play. It must be possible to retract the airbrake, even if it is pressed backwards in direction of flight. If there is any water in the airbrake box this has to be removed;
 - d) check the locking of the rear wing attachment pin.
6. Powerplant and brake fluid level:-
 - a) all screwed connections and their securing
 - b) function of throttle, and propeller brake
 - c) ignition system incl. wires and the spark plug connectors for tight fit
 - d) Check drive belt for wear and correct tension, sudden loss of tension indicates damage of the engine assembly
 - e) engine retaining cable and its connections in the engine compartment and at the engine
 - f) fuel lines, electrical wires, bowden cables and structural parts for wear and kinks.
 - g) exhaust muffler, propeller mount, cooling air guides, mechanical fuel pump and accessories for tight fit and any cracking.
 - h) apply strong pressure to the propellermount in forward, backward and sideward directions to check if the bolted connection between the engine block and the propeller mount or any thing else is loose or damaged. Check the rubber engine mounts also.
 - i) visual check of the propeller
 - j) turn the propeller 1 revolution by hand and listen for abnormal sounds which may indicate engine damage
 - l) drain condensed water from the fuel tank. The drainer is located in the main wheel box on the rear wall on the right hand side.

Flight manual DG-1000T

- m) check the outlet of the fuel tank ventline for cleanliness, the outlet is located behind the landing gear box.
 - n) check if the propeller-stopper will be pressed forward by its gas-strut, the powerplant must be in the position propeller-stopper extended for this check.
 - o) check the brake fluid level, the reservoir is installed in the front of the engine compartment;
 7. Tail wheel:-
 - a) check for wear, free play and excessive dirt in the wheel box. Remove excessive dirt prior to take off;
 - b) check tyre pressure: 4 bar -58 psi;
 8. Rear end of the fuselage:-
 - a) check the lower rudder hinge and the connection of the rudder cables for wear, free play and correct securing;
 - b) check the bulkhead and fin trailing edge shear web for cracks and delamination;
 9. Fin - horizontal tail:-
 - a) check the upper rudder hinge for wear and free play;
 - b) check the elevator for free play and correct control hook-up , look from the rear into the gap at the right hand side of the rudder;
 - c) check the securing of the stabilizer;
 - d) check the horizontal tail for free play;
 - e) check the TE or Multiprobe for correct insertion and fix it with tape
 - f) check the trim-weight box, correct number of weights, locking device completely engaged?
- Caution:** When changing the trim ballast check condition and correct gluing of the foam rubber rings to the mounting plate of the optical sensors in the trim-weight box. Without rings an indication error of the control lamp in the front instrument panel might occur. Replace missing rings according to Service Info 67-07(attached to the maintenance manual).
- g) check if a fin battery is installed: If the ends of the locking bow are visible on both sides in the fairings at the upper end of the fin this is the indication that no battery is installed.
 10. Right wing see item 5.
 11. Fuselage nose
 - a) check the ports for the static pressure and the pitot pressure and for the PC pressure (at the lower fuselage side) for cleanliness.
 - b) if the motorglider was parked in rain, you have to empty the static ports by sucking out the water at the ports.
 - c) check the nose hook for cleanliness and corrosion.

Flight manual DG-1000T

4.4 Pre-flight inspection

1. Lead ballast (for under weight pilot)?
2. Parachute worn properly?
3. Safety harness buckled?
4. Front seat: pedals adjusted?
Rear seat: seating height adjusted?
5. All controls and knobs in reach?
6. Altimeter?
7. Dive brakes cycled and locked?
8. Positive control check? (One person at the control surfaces).
9. Fin ballast tank emptied or correct amount filled in?
10. Trim-weight box in the fin, correct amount installed?
Locking device completely engaged?
11. Battery in the fin? Loading chart regarded?
12. Trim?
13. Fuel level?
14. Fuel cock open?
15. Both canopies locked?
16. Runway free?

Flight manual DG-1000T

4.5 Normal procedures and recommended speeds

4.5.1 Launch

Due to the towhook position being in the middle of the fuselage and the excellent effectiveness of the ailerons and rudder, the possibility of wing dropping or ground loops, even on a slowly accelerating aerotow is reduced. Take-off with strong crosswind is possible.

4.5.1.1 Aerotow

- a) Aerotow is permitted only using the nose tow release. Set trim to neutral for aerotow.
- b) Version with nose wheel: Pull the stick until the nose wheel lifts off from the ground. Then control the aeroplane so that nose wheel and tail wheel don't touch the ground.
Version without nose wheel: Keep the elevator in neutral position. Don't try to lift off before you reach an airspeed of 80 km/h (43 kts.) (without ballast). On a rough airfield hold the control stick tight. The undercarriage can be retracted at safety height during the tow.
Normal towing speed is 120-130 km/h (65 - 70 kts.).
For a cross country tow the speed can be as high as 185 km/h (98 kts.).

Warning: Aerotow with high take-off weight requires a powerful tow plane. Many tow planes are not certified to tow gliders with high take-off weights. Reduce the take-off weight if necessary!

Note: Aerotowing behind slow tow planes eg. Ultralight planes or touring motorgliders:

The take-off distance may be remarkably reduced if the DG-1000T is towed with the engine extended and running at full power.

Recommended towing speed is 100km/h (54 kts.).

Starting the engine on the ground: extend the powerplant via the manual extension-retraction switch, start the engine in the same manner as described in section 4.5.4.1.

To ensure good communication with the tow pilot the use of a headset is recommended at least for the pilot in command.

Warnings:

1. Due to the shorter take-off distance the aerotow with engine extended and running is safer than with engine retracted. Nevertheless this take-off procedure is only permitted if the conditions are such that a tow with engine retracted will also be safe.
2. If the engine of the DG-1000T fails the tow must be terminated by releasing the towing cable, this procedure is applicable as long as the aircraft are still on the ground.

Flight manual DG-1000T

3. The DG-1000T pilot should keep his left hand at the throttle handle to enable him to close the throttle immediately in case the tow-plane terminates the tow (This is a standard procedure for powered aircraft pilots).
4. In case of termination of the tow when the DG-1000T is still on the ground close the throttle immediately, then release the towing cable and apply the wheel brake.
5. In case of termination of the tow when the DG-1000T is already in the air take the hand from the throttle, release the towing cable and continue the climb with full throttle. This is still applicable in case the tow plane remains on the ground.
6. If the tow is so fast that the DG-1000T engine may overspeed reduce the throttle as necessary. For a fast cross country tow the powerplant must be retracted.

4.5.1.2 Winch launch

Winch launch is only allowed using the C.G. tow hook!

Set the trim to neutral for winch launch.

Caution: During ground roll and initial take-off (especially when flying solo) push the control stick to a forward position to prevent excessive nose-up pitching rotation during initial take-off.

After reaching safety altitude gradually pull back on the stick, so that the glider will not pick up excessive speed. Don't pull too hard.

After reaching release altitude pull the tow release knob.

Recommended winch launch airspeed 110-130 km/h (60-70 kts.).

Caution: Do not fly at less than 90 km/h (49kts.) or not more than 150 km/h (81 kts.).

Warning: Winch launch with high take-off weight requires a powerful winch!

4.5.2 Free flight

Stalling characteristics (level and turning flight)

When stalled the DG-1000T will warn by buffeting. If the stick is pulled further the DG-1000T will drop one wing.

Only at forward C.G. positions the DG-1000T can be flown in stall without wing dropping, maintain control during stalled flight only with the rudder, holding the ailerons neutral.

With stick forward and opposite rudder if required, the DG-1000T can be recovered without much loss of height. Rain does not influence this behaviour noticeably. The loss of height is approx. 50 m (160 ft).

Stall airspeeds see section 5.2.2.

Caution: Flights in conditions conducive to lightning strikes must be avoided.

Flight manual DG-1000T

4.5.3 Cruise engine on

4.5.3.1 General

The engine of the DG-1000T is not designed for continuous cruise with the engine. Due to the drag of the extended powerplant and as the propeller is designed for optimum climb performance, cruise with higher speed is not efficient.

The optimum cruise is with the so called sawtooth technique. After climb with V_y retract the engine and glide with airspeed according to the Mc Cready theory, flying slowly in lift and faster in sinking air.

The medium cruise speed achieved by sawtooth technique is not much less than for level engine on cruise, but the range will be 1.5 times longer.

Performance data see sect. 5.3.5.

4.5.4 Powerplant extension-retraction in flight

4.5.4.1 Extension and starting the engine in flight

1. With the engine extended but not running the rate of sink at 90 km/h (49 kts) increases to 1.5 m/sec. (300 ft/min.).

Therefore restarting the engine should only be done over landable terrain and not below 400 m (1320 ft) above ground. But it is better to restart the engine at 200 m (660 ft) over a landable field rather than at 400 m (1320 ft) over a forest or unlandable scrub.

Should a flight be conducted over a wide expanse of unlandable terrain, the engine should then be restarted at 1000 m (3300 ft) above ground level so that if the engine does not start, all the emergency starting procedures can be followed unhurriedly including retraction of the engine if necessary.

2. In a normal restarting situation the loss of altitude from starting the extension procedure until the engine is running is only about 20 m (70 ft).
3. Extension: Fly at 80-90 km/h (43-49 kts). Check if the primer switch is in the "auto" position and if the fuel cock is open. Throttle on idle, switch on the ignition. The engine will extend by itself. You may press the starter button before the engine is extended completely. The starter motor will start the engine as soon as the powerplant is extended. When the engine fires, release the starter button and move the throttle slowly to full throttle.

In case of starting problems see sect. 4.5.4.3.

Warning: If after starting the engine the failure message "Starter Run" will be displayed, the starter motor didn't disengage and produces electric power, stop the engine immediately to prevent damage of the electrical system.

4.5.4.2 Stopping and retracting the engine in flight

1. Fly at 85-90 km/h (46-49 kts).
2. Bring the throttle back to idle.
3. Switch off the ignition.
4. The powerplant will be automatically retracted a certain distance to reduce the rotational forces on the propeller. The propeller will slow down by itself.
5. The powerplant will be automatically retracted another 5° and the propeller stopper moves forward in the propeller circle. If the propeller is already in the position for retraction (close to the stopper) the powerplant will retract by itself.
To save altitude you may turn the propeller into the position for retraction (ignition switched off) by pressing the starter button. The starter motor receives only pulses of electric power to turn the propeller slowly. As soon as the propeller is in retraction position, the electric power to the starter motor is cut off.
6. If turning the propeller via the starter motor doesn't work, you may turn the propeller by flying faster. Watch the procedure in the rear view mirror.
7. As soon as the propeller is in the position for retraction (close to the stopper) the powerplant will retract by itself.
8. If the automatic retraction doesn't work, the powerplant may be retracted via the manual extension-retraction switch.

Caution: It is possible that the propeller might stop just above the propeller stopper and can press on the stopper during powerplant retraction into the position where the stopper shall move forward. The stopper can't move forward and operates the switch in this position. To avoid any damage the powerplant will not retract completely. To accomplish this the DEI-NT checks within 3 seconds if the switch has been operated. If not, the powerplant will be extended automatically to the powerplant position where the propeller usually should stop turning.

Rotate the propeller out of this position by pressing the starter button, further powerplant retraction is as usual.

Note: only in this special case is it possible to rotate the propeller with the starter motor in this powerplant position (position where the propeller should usually stop turning).

4.5.4.3 Starting problems

The engine is equipped with electric fuel injection (primer) instead of a choke valve. The automatic control of the primer enables engine starting with little risk of misoperation.

To inspect the correct functions of the primer the DEI-NT displays a syringe symbol as long as fuel is injected (primer valve open). With a cold engine fuel will also be injected after releasing the starter button. The duration of the injection is dependent on the cylinder head temperature. With CHT above 40°C (104°F) no fuel will be injected during engine start.

- a) If you suspect that the engine is flooded, e.g. CHT just below 40°C (104°F) and primer working, you should switch off the primer and try to start the engine with full throttle. If the engine starts, wait until 3000 RPM are reached, then reduce throttle to keep approx. 3000 RPM. If the engine is flooded excessively you may close in addition the fuel cock. As soon as the engine starts open the fuel cock again.
- b) If with normal CHT (+5°C (41°F) up to +38°C (100°F)) the engine does not fire this may be a hint that the fuel filter is dirty and so the amount of fuel injected is reduced.
The filter has to be cleaned or replaced before take off.

4.5.5 Approach and landing

Note: Always land in the gliding configuration, engine retracted, except in an emergency.

4.5.5.1 Normal landing

It is recommended to dump the waterballast before landing even on airfields. Dump the ballast before an outlanding in any case.

Abeam the landing point extend the landing gear. In calm weather approach with approx. 100 km/h (54 kts.) (ballast dumped!). With strong wind and / or waterballast fly faster! The very effective Schempp-Hirth dive brakes make a short landing possible.

Slipping may be used as additional landing aid.

Caution: While side-slipping the rudder is held in its deflected position by the airflow. So it is recommended to practice slipping at a higher altitude.

The slip can be introduced at the recommended approach speed see above. To recover from the slip neutralize the aileron control first, this will reduce the force which sucks the rudder in its displaced position. During the slip the airspeed indicator shows airspeed values which are too low, so the slip must be executed with regard to the position of the horizon. No influence on the slipping characteristics when slipping with partially filled waterballast is noticeable.

Strong crosswind offers no problem.

Do not approach too slowly with fully extended airbrakes otherwise the aircraft may drop during flare out. When flaring out keep the airbrake setting you were using, opening them further may drop the motorglider!

You can land the DG-1000T on soft fields with the landing gear extended, as there is no tendency of nosing over. During touch down pull the stick completely to avoid the fuselage nose touching the ground.

After landing in a muddy field clean the landing gear and tow releases. Dirt in the front strut can keep the landing gear from locking over centre next time.

With TN1000/13 executed, standard from ser. no. 10-133 on:

Dirt in the landing gear positive locking device (notch and latch at the landing gear struts).may keep the latch from engaging in the notch next time. Simply hosing with water is the best cleaning method (don't use a high pressure cleaner).

4.5.5.2 Landing with the engine extended and stopped

See emergency procedures sect. 3.18.
Land with the engine extended only if the engine can't be retracted.

4.5.5.3 Landing with the landing gear retracted

Wheel-up landing is not recommended see emergency procedures section 3.10.

After wheel-up landing check the fuselage belly and the tow hook for damage.

4.5.5.4 Landing with asymmetric waterballast

See emergency procedures section 3.8

4.5.6 Engine retraction on the ground

Caution:

After ground test runs don't retract the powerplant immediately. Allow the engine to cool down several minutes.

For retraction turn the propeller by hand into position, don't use the starter motor.

The engine will be retracted automatically. To interrupt the retraction procedure proceed as follows:

Push the manual switch up or down to switch off the automatic system. Further retraction via the manual switch or by switching the ignition on and off.

4.5.7 Flight with water ballast

4.5.7.1 Wing tanks

Recommended ballast for smooth thermals:

	rate of climb		ballast	
	m/s	fpm	litres	U.S. gallons
below	1,5	300	None	
	1,5 – 3	300-600	40	10
more than	3	600	max. ballast	

Do not exceed the maximum gross weight when loading the water ballast. The maximum quantity of water allowed is dependent on the empty weight and the cockpit load (see section 6.8.5).

In flight the water drains at approx. 0.5 lt./sec. (1.1 lbs./sec).

4.5.7.2 Fin water ballast tank

For optimal thermalling performance and handling water ballast in the fin tank should be used to compensate the forward movement of C.G. due to the mass of the wing water ballast. Please refer to section 6.8.6.

Warning: It is prohibited to use the fin tank in icing conditions see sect. 2.18.

Warning: If there is the risk of freezing, dump all water before you reach freezing altitude, latest at +2°C (36°F), or descend to lower altitudes.

If you suspect a tank is leaking, dump all water immediately.

Water ballast raises the approach speed, so it is recommended to dump the waterballast before landing. Dump the ballast before an outlanding in any case.

4.5.7.3 Filling the waterballast

See sections 4.2.2 and 0.1.1. After filling level the wings and check if the dump valves are tight. It is not allowed to fly with leaking watertanks as this may result in an asymmetric loading condition.

4.5.7.4 Dumping of the waterballast

First open the fin tank, then open both wing ballast tanks together. Do not empty one wing tank after the other to avoid an asymmetric loading condition.

Warning: If the fin ballast dump valve handle can be operated with unusually low effort (force of the retaining spring is no more apparent) you must suspect that the fin ballast can't be dumped any more. In such case don't dump the wing ballast to avoid an unsafe backward C.G. position.

4.5.7.5 Valves leaking, servicing

Please refer to the maintenance manual sect. 1.8 and 4.1.

4.5.8 Flight at high altitude and at low temperatures

With temperatures below 0°C (32°F) for instance when wave flying or flying in winter, it is possible that the control circuits could become stiffer. Special care should be taken to ensure that there is no moisture on any section of the control circuits to minimize the possibility of freeze up. It could be advantageous to apply Vaseline along all the edges of the airbrake cover plates to minimize the possibility of freezing closed.

Operate the controls regularly to prevent ice build-up.

It is not allowed to carry waterballast.

Caution:

1. At temperatures below -20°C (-4°F) there is the risk of cracking the gelcoat.
2. Attention must be paid to the fact that at higher altitudes the true airspeed is greater than the indicated airspeed.

The max. speed V_{NE} is reduced. See the following table:

Altitude in [m]	0-3000	4000	5000	6000	7000	8000
V_{NE} indicated km/h	270	256	243	230	217	205

Altitude in [ft]	0-10000	13000	16000	20000	23000	26000
V_{NE} indicated kts.	146	138	131	124	117	111

3. Dump the water ballast before you reach freezing altitude or descend to lower altitudes.
4. Do not fly below 0°C (32°F) when your glider is wet (e.g. after rain).

Flight manual DG-1000T

4.5.9 Flight in rain and thunderstorms

With light rain the stall speed and the sink rate increases slightly and the approach speed has to be increased.

Warning: Flights and especially winch launches in the vicinity of thunder storms should be avoided. Due to lightning discharge, carbon fibre structures may be destroyed.

4.5.10 Cloud flying

Cloud flying is only permitted without waterballast. Take care to fly smoothly and coordinated. It is prohibited to use a spin as a method for reducing altitude in cloud. In case of emergency, pull out the dive brakes fully before exceeding a speed of 200 km/h and dive with max. 200 km/h (108 kts.) to leave the cloud.

Warning: Flying in or near thunderstorm-clouds is prohibited.

Note: Cloud flying is not permitted in Canada and Australia.

Flight manual DG-1000T

4.5.11 Aerobatics

Caution: The DG-1000T is a high performance motorglider. Therefore the speed increase in the dive, especially in inverted flight is high. Training aerobatics therefore should only be executed after a rating with an experienced pilot, or if you can master the manoeuvres on other motorglider types.

In any case don't try to execute the manoeuvres with entry speeds other than those listed.

Caution: Do not make full or abrupt control movement above the manoeuvring speed $V_A=185$ km/h (97 kts.). At speeds between V_A and $V_{NE}=270$ km/h (146 kts.) reduce the control movements accordingly. At V_{NE} only 1/3 of the max. control movements are allowed.

4.5.11.1 Category U, Utility

Warning: Execute only the approved manoeuvres.

Approved manoeuvres valid for all spans, but only without waterballast, powerplant retracted or removed and with the weight of the rear pilot compensated by ballast in the ballast box in the fin see section 6.8.7.

Approved manoeuvres	Entry speed	g-loads
Spin	/	/
Inside loop	180 - 200 km/h (97 - 108 kts)	4.0
Chandelle	180 - 200 km/h (97 - 108 kts)	3.5
Lazy Eight	180 - 200 km/h (97 - 108 kts)	3.5
Stall turn	200 - 220 km/h (108 - 119kts)	4.0

Spins

Caution: Prolonged spinning is satisfactorily accomplished with aft C.G. positions. If prolonged spinning is intended, ballast in the ballast box in the fin should be used to achieve an aft C.G. position, see section 6.8.7.

It is not necessary to extend the dive brakes during spin recovery. The DG-1000T displays a large nose down pitch attitude after leaving the spin. So you have to flare out correspondingly.

With **medium and forward C.G. positions** prolonged spinning is not possible. The DG-1000T will terminate the spin by itself after a certain number of turns dependent on the C.G. position. The nose down pitch and speed will be high so with these C.G. positions not more than 1 turn spins should be executed, to avoid high g-loads.

In addition there is a tendency that the spin will turn into a spiral dive after 1 or 2 turns. On reaching this state you must recover immediately.

Inducing the spin: Gradually bring the motorglider into a stall. When buffeting starts, pull the stick back completely and kick in full rudder in the direction of spin.

Recovering from the spin: Apply full rudder opposite to the direction of spin, then ease stick forward until the rotation ceases, centralize the controls and carefully pull out of the dive. The ailerons should be kept neutral during recovery. Height loss during recovery is approx. 100 m (320 ft), the max. speed is 200 km/h (108 kts.).

Stall turn

To fly a stall turn safely, proceed as follows:

Don't choose an entry speed of less than 200 km/h (108 kts.).

During the pull out, when reaching the vertical flight path initiate rotation at min. 150 km/h (81 kts.) with the rudder. Push the rudder quickly, but not abruptly. During the turn apply a little aileron against the direction of turn and full forward stick deflection to execute the turn correctly in one plane.

As soon as you reach the vertical dive, start to pull out of the dive to minimize the increase of airspeed and the g-loads.

Be careful not to exceed the airspeed for max. control surface deflection as indicated in section 2.2.

Caution: A classical stall turn with almost no airspeed at the highest point of the turn is very difficult to fly with a glider with larger wingspan, due to the high moment of inertia.

This effect is taken into account when using the above mentioned procedure.

Only a pilot who is trained in the technique to execute during the pull up a slight side-slip (with a little aileron deflection in the intended turn direction and appropriate rudder deflection against turn direction) can start to initiate the rotation at a lower speed of 120 km/h (65 kts.) with fast rudder deflection. The turn will look nicer and be narrower than with the method described above.

Warning: If the rudder is applied too late and the rotation is insufficient, it is possible that the glider tailslides (falls tailwards) or falls sideways. If this happens it is important to hold all controls firmly, preferably at one of the stops, until the nose swings down. Then, immediately perform a flare out. Otherwise, due to the reverse airflow, the control surfaces may flap against their stops and be damaged. In addition holding the control stick at the stop prevents the stick from making unnecessary movements due to the massbalance weights in the elevator control system.

Flight manual DG-1000T

4.5.11.2 Category A, Aerobatic

Only approved with 18m span, powerplant retracted or removed and without waterballast, max. mass 630 kg (1389 lbs.) and with the weight of the rear pilot compensated by ballast in the ballast box in the fin see section 6.8.7 and with the required equipment installed see section 2.13.

Execute only the approved manoeuvres.

Don't execute aerobatics below the safety altitude required by national law.

Approved manoeuvres (Category A, Aerobatic):

All manoeuvres approved for category U, Utility and additionally:

Approved manoeuvres	recommended airspeed	g-load
Inverted flight	120 - 200 km/h (65-108 kts.)	-1
Approved manoeuvres	entry speeds	g-loads
half loop and half roll	220 km/h (119 kts.)	+5.0
half roll and half loop	180 – 200 km/h (97-108 kts.)	+4.5
slow roll	180 - 200 km/h (97-108 kts.)	+/-1.5
half positive flick roll from normal to inverted flight with half pos. loop	120 - 140 km/h (65 - 76 kts.)	+4.0
half negative flick roll from inverted to normal flight	130 – 150 km/h (70 - 81 kts.)	-3.5

Combinations of the approved manoeuvres

Caution: the DG-1000T is equipped with a powerful longitudinal trimming device. In addition the mass balance weight of the elevator is incorporated in the elevator control system. Due to these facts the elevator control forces during inverted flight change considerably with trim position.

It is strongly recommended to trim the glider to approx. 140 km/h (76 kts.) in horizontal flight prior to executing aerobatics, especially prior to inverted flight.

Flight manual DG-1000T

Inverted flight

The speed in inverted flight should preferably be chosen between 120-200 km/h (65-108 kts.). At speeds greater than 185 km/h (100 kts.) no full control deflections are allowed.

Warning:

When the speed is reduced below the minimum speed (depending on weight and C.G. position between 105 - 115 km/h, 57 - 62 kts.) the DG-1000T will stall.

The stall will be indicated by buffeting of the tailplane. The stall starts with the stick somewhat away from its forward position. When applying full stick forward the DG-1000T will enter an inverted stable stall with high sink-rate.

The aircraft nose will noticeably point below the horizon and the airspeed increases. The efficiency of the ailerons and rudder will not be reduced.

To avoid an uncontrolled flight condition or disorientation of the pilot, this manoeuvre should be terminated immediately by a half roll!

Half loop and half roll

After reaching the entry speed of 220 km/h (119kts.) pull the stick quickly, but not abruptly until reaching the inverted position.

Before the nose starts pointing below the horizon apply full aileron in the desired direction to induce the half roll. When the wing passes the vertical position the rudder must be applied upwards to keep the nose above the horizon.

Half roll and half loop

After reaching the entry speed of 180 - 200 km/h (97 - 108 kts.) the nose must be raised approx. 30° above the horizon. After returning the stick to neutral apply full aileron into the desired direction to start the half roll. When the wing passes the vertical position the rudder must be applied upwards. When reaching inverted flight the ailerons must be neutralized and before reaching the stall speed pull back the stick, but not too abruptly, to start the half loop to level out.

Note: If during the entry the nose is raised too high or the entry speed is too low, it can happen, that the glider continues to roll into normal upright position, even if the aileron was neutralized in inverted position .

Flight manual DG-1000T

Slow roll

After reaching the entry speed of 180 - 200 km/h (97-108 kts.) the nose must be raised slightly above the horizon. After returning the stick to neutral, full aileron has to be applied in the desired direction.

When the wing passes the vertical position the rudder must be applied a little in upwards direction.

After the wing has passed the first vertical position the stick is to be pushed slightly (never abruptly) forward to keep the nose above the horizon. When the wing passes the second vertical position the rudder must be applied upwards to keep the nose above the horizon until normal flying position is reached.

Note: If during the inverted flight the nose is raised too high above the horizon and the speed is reduced too much, a stall could occur when the wing reaches the second vertical position and the roll is finished as a "flicked" roll. The stall is indicated by buffeting of the tailplane.

Flight manual DG-1000T

Flick manoeuvres

The flick manoeuvres which have been tested with the DG-1000T should only be executed by experienced aerobatic pilots. The result is dependent as for any other motorglider on several parameters like inducing control speed, C.G. position, control movement during rotation etc.

Due to the large span and the resulting large moment of inertia, executing flick manoeuvres is more difficult than with smaller aerobatic gliders. Therefore you should not try these manoeuvres solo unless you have trained and mastered them on other gliders

Half positive flick roll from normal to inverted flight with half positive loop

Tested entry speed: 120 – 140 km/h (65 – 76 kts.).

Prior to inducing the flick roll, place the nose a little below the horizon.

Induce the half roll with full stick backwards and full rudder only. After the rotation starts ease the stick to neutral to avoid too large an angle of attack and unnecessary loss of speed.

Stop the rolling motion in the inverted position by neutralizing the elevator control and with a little rudder against the rolling direction. Then pull the stick back to fly the half positive loop before the glider stalls in the inverted attitude. If you keep the stick pulled back for too long a time during entry, it may not be possible to stop the rotation in the inverted attitude and the glider will continue to roll into normal flight position.

Half negative flick roll from inverted to normal flight

Tested entry speed: 130 – 150 km/h (70 – 81 kts.).

Induce the half roll with full stick forwards and full rudder only. If you use additional aileron there may be some vibration in the fuselage due to vortices. The vibrations don't impair the flight characteristics.

Shortly before reaching normal upright position, the rotation has to be stopped by pulling the stick backwards and applying some opposite rudder.

Stopping the half roll in exactly horizontal attitude is nearly impossible. The glider will adopt a nose down position.

4.6 Flight with the engine removed from the aircraft

The DG-1000T can be flown without the engine when the engine is sent for a major overhaul, or removed to decrease the aircraft empty weight for competition flying or for aerobatics.

The following items must be executed: (see sect. 4.10.6 in the maintenance manual).

1. Remove the powerplant incl. the engine extension-retraction mechanism.
2. In addition to the on-board battery install a battery in the fin see section. 7.17.6.

1 kg = 2.2046 lbs	0.305 m = 1 ft		
		C.G. behind	
	mass	datum	moment
	kg	m	kgm
mass reduction			
engine with			
propeller	-39,65	1,253	-49,68
			0,00
additional mass			0,00
battery in the fin	5,5	5,340	30,71
total difference	-33,90	(0,560)	-18,97

3. Secure the limit switch for engine retracted (in the rear of the engine compartment) with a Ty-rap in the activated position. Otherwise the DEI-NT will remain in the power flight mode and the goose neck microphones won't be activated.
4. Tape the engine doors carefully with fabric tape.
5. Carry out a C.G. calculation according to section 6.9. The inflight C.G. will be moved forward by approx. 8 mm (0.3 in.) depending on the flightmass and empty mass C.G.

Note: After switching on the main switch some failure messages will be displayed. Confirm each message by pressing the selector switch to eliminate the message.

5 Performance

Section	Page
5.1 Introduction.....	5.2
5.2 Approved data.....	5.3
5.2.1 Airspeed indicator system calibration.....	5.3
5.2.2 Stall speeds.....	5.4
5.3 Additional Information.....	5.5
5.3.1 Demonstrated crosswind performance.....	5.5
5.3.2 Gliding performance.....	5.5
5.3.3 Flight polar with 20 m wing span.....	5.6
5.3.4 Flight polar with 18 m wing span.....	5.7
5.3.5 Performance under power.....	5.8
5.3.6 Noise data.....	5.9

5.1 Introduction

This section provides approved data for airspeed calibration, stall speeds and non-approved additional information.

The data in the charts has been computed from actual flight tests with the motorglider in good and clean condition and using average piloting techniques.

5.2 Approved data

5.2.1 Airspeed indicator system calibration

IAS = indicated airspeed

CAS = calibrated airspeed

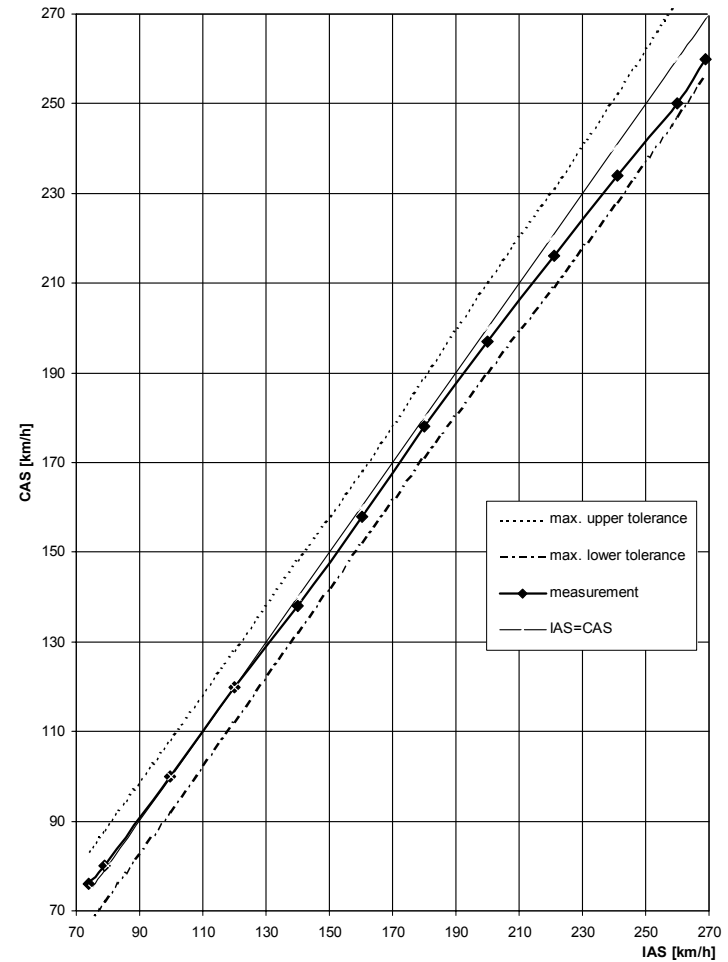

1 kts = 1 km/h / 1.852

Caution: The airspeed indicator is to be connected to the static ports and pitot probe in the fuselage nose.

Flight manual DG-1000T

5.2.2 Stall speeds

The given speeds are the minimum achievable speeds during level flight in km/h and (kts.).

Airbrakes retracted 20m span

mass kg	470	500	550	600	650	700	750
mass lbs.	1036	1102	1213	1323	1433	1543	1653
W/S kg/m ²	26,8	28,5	31,4	34,2	37,1	39,9	42,8
W/S lbs./ft. ²	5.5	5.84	6.43	7.01	7.59	8.18	8.76
V km/h	62,9	64,9	68,0	71,1	74,0	76,8	79,5
V kts.	34	35	36.7	38.4	40	41.5	42.9

Airbrakes retracted 18m span

W/S kg/m ²	28,1	29,9	32,9	35,9	38,9	41,9	44,9
W/S lbs./ft. ²	5.76	6.12	6.43	7.35	7.96	8.57	9.18
V km/h	64,4	66,4	69,7	72,8	75,8	78,6	81,4
V kts.	34.8	35.9	37.6	39.3	40.9	42.4	44

Airbrakes extended 20m span

mass kg	470	500	550	600	650	700	750
V km/h	67,4	69,5	72,9	76,2	79,3	82,3	85,1
V kts.	36,4	37,5	39,4	41,1	42,8	44,4	46,0

Airbrakes extended 18m span

V km/h	69,0	71,2	74,7	78,0	81,2	84,2	87,2
V kts.	37,3	38,4	40,3	42,1	43,8	45,5	47,1

The loss of height for stall recovery is approximately 30 m (100 ft) if recovered immediately.

Flight manual DG-1000T

5.3 Additional Information

5.3.1 Demonstrated crosswind performance

The demonstrated crosswind velocity is 15 km/h (8 kts) according to the airworthiness requirements.

5.3.2 Gliding performance

1 kts= 1 km/h / 1.852, 1 m/s= 197 ft/min.= 1.94 kts, 1 kg/m²= 0.2048 lbs/ft²

Performance data with **20 m** span (S = 17,53 m²)

wing loading	kg/m ²	28	35	42
minimum sink	m/s	0,51	0,56	0,62
at	V [km/h]	79	88	98
best glide ratio	/	45,9	46,3	46,6
at	V [km/h]	93	104	120

Performance data with **18 m** span (S = 16,72 m²)

wing loading	kg/m ²	30	36	45
minimum sink	m/s	0,60	0,65	0,72
at	V [km/h]	84	90	100
best glide ratio	/	41,5	41,7	42
at	V [km/h]	100	110	123

A variation in speed by ± 10 km/h (5 kts.) from the above will decrease the best glide angle by 0.5 glide points and increase the min. sink rate by 1 cm/sec. (2 ft/min).

The polar curves can be seen on the next page.

For optimum performance, the aircraft should be flown with a C.G. towards the rear of the allowable range. This especially improves thermalling performance. However the aircraft will be more pitch sensitive.

The wing fuselage joint, wing parting and the tailplane fin joint should be taped up and the aircraft thoroughly cleaned to obtain maximum performance.

The polars apply to a "clean" aircraft.

With dirty wings or flight in rain, the performance drops accordingly.

5.3.3 Flight polar with 20 m wing span

1 kts= 1 km/h / 1.852, 1 m/s= 197 ft/min.= 1.94 kts, 1 kg/m²= 0.2048 lbs/ft²

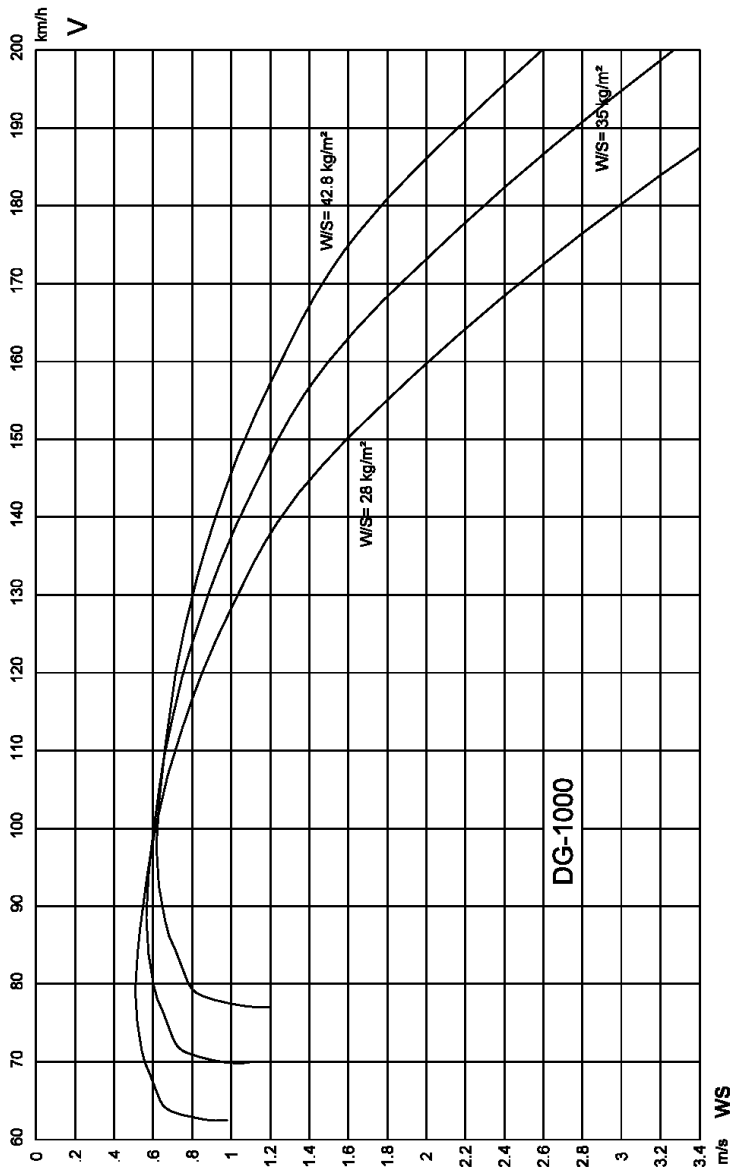

5.3.4 Flight polar with 18 m wing span

1 kts= 1 km/h / 1.852, 1 m/s= 197 ft/min.= 1.94 kts, 1 kg/m²= 0.2048 lbs/ft²

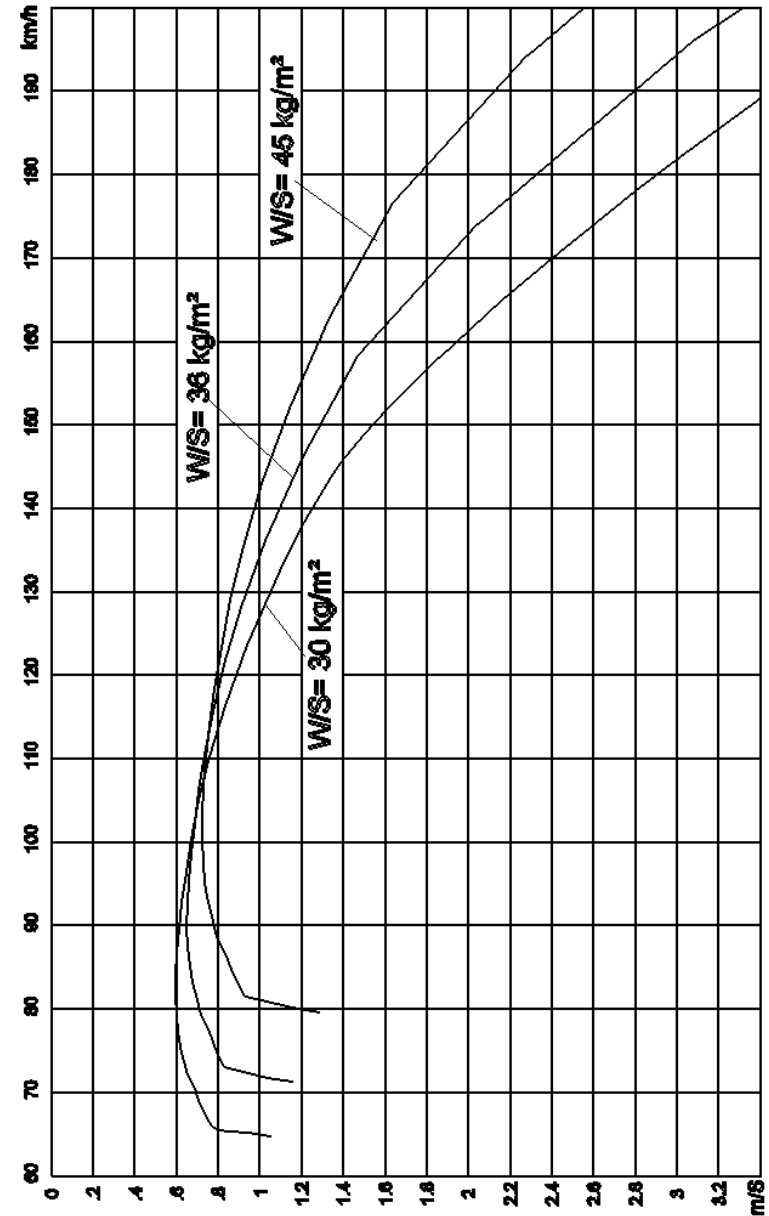

5.3.5 Performance under power

5.3.5.1 Rate of climb

Measured rates of climb for 15°C (59°F) at MSL.

15°C increase in temperature reduces the rate of climb by ca. 0.2 m/s (40 ft/min.).

R/C = climb rate at $V_y = 90$ km/h (49 kts.) and with flap setting +8°

H = altitude above sea level

1 m/s = 197 ft/min. = 1.94 kts., 1 m = 3.2809 ft, 1 kg = 2.2046 lbs

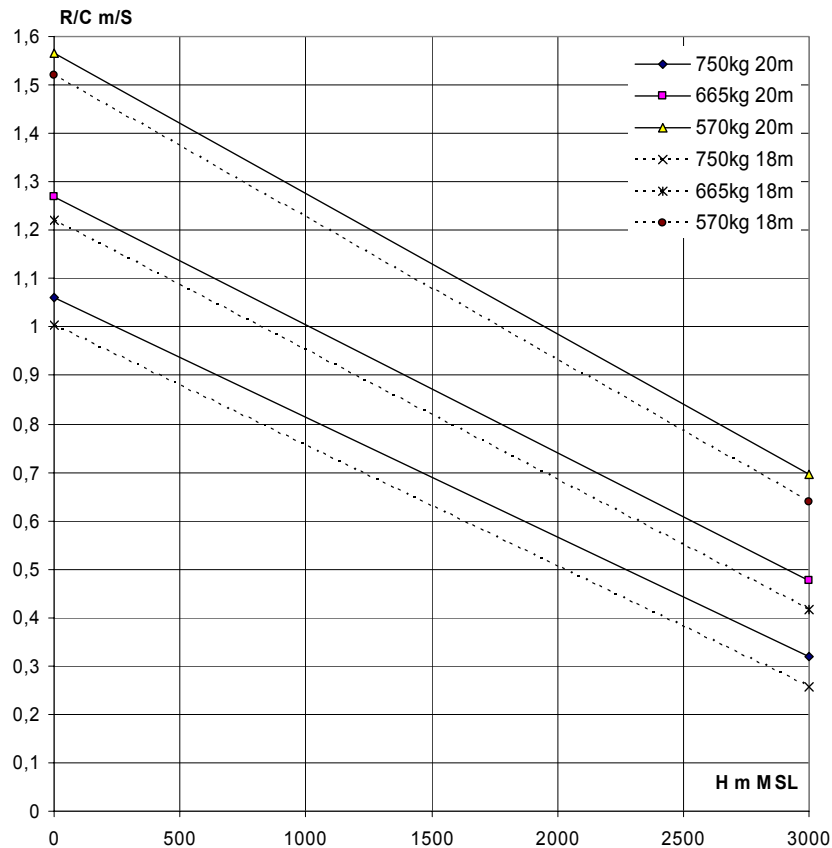

5.3.5.2 Cruising Flight

The cruising speed is approx. 127 km/h (69 kts.) with maximum continuous power 6100 RPM.

5.3.5.3 Maximum operational altitude

The maximum operational altitude is more than 4000 m (13100 ft) MSL.

For continuous operation at higher altitudes, the main nozzles in the carburetors may be set to a smaller fuel flow in accordance with the engine manufacturer.

5.3.5.4 Maximum Range (without reserve)

Take-off mass 665 kg, 1470 lbs. wingspan 20 m

1. At cruising speed with full fuselage tank (22 l, 5.8 US gal) = approx. 230 km, 124 nm. This is 10.4 km/l; 21 nm/US gal.

2. With saw-tooth flight technique Mc Cready O with full fuselage tank (22 l, 5.8 US gal) = max. 370 km; 200 nm. This is 16.8 km/l, 34 nm/US gal

These values can only be achieved with still air and exact speed control.

3. With saw-tooth flight technique Mc Cready 1 with full fuselage tank (22 l, 5.8 US gal) = max. 327 km; 176 nm. This is 14.8 km/l, 30 nm/US gal.

The values for saw-tooth technique are for beginning the climb at 500 m (1640 ft) MSL and a climb of 1000 m (3280 ft).

5.3.6 Noise data

Noise requirements: LVL, section 3: self sustaining powered sailplanes

Measured noise level: 60,4 dB(A)

Noise limit: 66 dB(A)

6 Mass (weight) and balance

Section	Page
6.1 Introduction.....	6.2
6.2 Weighing procedures	6.2
6.3 Weighing record.....	6.2
6.4 Basic empty mass and C.G.	6.2
6.5 Mass of all non-lifting parts (WNLP).....	6.3
6.6 Max. mass (weight).....	6.3
6.7 Useful loads	6.3
6.8 Loading chart	6.4
6.8.1 Cockpit load	6.4
6.8.2 Removable ballast for underweight pilots	6.4
6.8.3 Baggage.....	6.4
6.8.4 Battery in the fin	6.5
6.8.5 Waterballast in the wing tanks (Option).....	6.5
6.8.6 Fin ballast tank (Option).....	6.5
6.8.7 Ballast box in the fin	6.6
6.8.8 Weighing report (for section 6.3).....	6.7
6.8.9 Empty weight C.G. limits (for 6.4).....	6.8
6.8.10 DG-1000 ballast chart (for 6.8.5).....	6.9
6.9 C.G. calculation	6.10

6.1 Introduction

This section contains the payload range within which the motorglider may be safely operated.

A procedure for calculating the in-flight C.G. is also provided.

A comprehensive list of all equipment available for this motorglider is contained in the maintenance manual.

6.2 Weighing procedures

See maintenance manual DG-1000T.

Datum: Wing leading edge at the rootrib.

Reference line: aft fuselage centre line horizontal.

The weighing is to be executed with all watertanks and the fuel tank emptied, without ballast in the trim ballast boxes in the fin and in the cockpit (optional) and without fin battery Z110 (Option), powerplant retracted.

6.3 Weighing record

The result of each C.G. weighing is to be entered on page 6.7. If the min. cockpit load has changed this data is to be entered in the cockpit placard as well. When altering the equipment, the new data can be gathered by a C.G. calculation (see section 6.9).

The actual equipment list is enclosed in the maintenance manual.

6.4 Basic empty mass and C.G.

Actual data see page 6.7. With the empty weight C.G. and the cockpit loads in the limits of the diagram on page 6.8, the in-flight C.G. limits will not be exceeded.

6.5 Mass of all non-lifting parts (WNLP)

The max. mass of all non-lifting parts is 554 kg (1221 lbs.).

WNLP is to be determined as follows:

WNLP = WNLP empty + cockpit load (pilots, parachute, baggage, trim ballast, fuel, waterballast in the fin, removable items of equipment etc.).

WNLP empty = Total empty weight incl. permanently installed equipment minus weight of the wings.

6.6 Max. mass (weight)

Category A „Aerobatic“

Maximum take-off and landing mass: 630 kg 1389 lbs.

Category „Utility“

with waterballast:

Maximum take and landing off mass: 750 kg 1653 lbs.

without waterballast: Maximum take-off and landing mass = $W_{NLP} + W_{wings}$

W_{NLP} = Maximum mass of all non lifting parts (see above)

W_{wings} = actual mass of the wings

6.7 Useful loads

Max. load **without** waterballast

= max. mass without waterballast - empty mass

Max. load **with** waterballast

= max. mass with waterballast - empty mass

The data is recorded on page 6.7.

6.8 Loading chart

6.8.1 Cockpit load

see weighing report section 6.8.8.

a) single seated:

max. load in the front seat 110 kg (242 lbs)

min. load in the front seat see placard in cockpit and weighing report

b) two-seated:

max. cockpit load is 210 kg (463 lbs.) with a max. of 105 kg (231 lbs.) in the front seat or 110 kg (242 lbs.) in the front seat and 90 kg (198 lbs.) in the rear seat.

min. cockpit load in the front seat is the min. cockpit load see a) minus 40% of the load in the rear seat.

c) With these loads, the C.G. range given under section 6.8.8 will be kept in the limits if the empty weight C.G. is in its limits.

With lower pilot weight necessary ballast must be added in the seat or in the optional ballast boxes see below. Ballast put on the seat (lead ballast cushion) must be fastened at the connections of the safety belts.

6.8.2 Removable ballast for underweight pilots

Option: Ballast boxes in the front cockpit for removable Ballast (trim weights), see section 7.17.1.

6.8.3 Baggage

max. 15 kg (33lbs)

Heavy pieces of baggage must be secured to the baggage compartment floor (screwing to the floor or with belts). The max. mass secured on one half of the floor (left and right of fuselage centre line) should not exceed 7,5 kg (16.5 lbs.).

The added load in the fuselage must not exceed the max. load without waterballast (W.B.) see weighing report section 6.8.8.

6.8.4 Battery in the fin

Only the use of the factory supplied battery Z110 (mass 5.5 kg, 12.1 lbs.) is permitted.

Only heavy pilots should install a battery in the fin.

The battery in the fin raises the min. front cockpit load by 16 kg (35 lbs.).

Note: The fin battery equals (concerning the C.G.) 39 kg pilot mass in the rear cockpit.

6.8.5 Waterballast in the wing tanks (Option)

The tanks have a capacity of 80 l (21,2 US gallons) per wing

The permitted amount of waterballast is dependent on the empty weight and of the load in the fuselage and can be determined from the diagram "**Ballast chart**" section 6.8.10.

It is only allowed to fly with symmetric wing ballast!

6.8.6 Fin ballast tank (Option)

Water ballast in the fin tank should be used to compensate the forward C.G. shift due to the water ballast in the wings.

The amount of ballast in the fin is dependent on the amount of water in the wing tanks and to be determined from the following table.

waterballast in the	
wings	fin
kg	kg
20	0,6
40	1,3
60	2,1
80	2,9
100	3,8
120	4,6
140	5,4
160	6,2
/	/

waterballast in the	
wings	fin
lbs.	lbs.
40	1,2
80	2,7
120	4,2
160	5,9
200	7,5
240	9,2
280	10,8
320	12,4
350	13,5

6.8.7 Ballast box in the fin

a) Compensation of the C.G. shift due to the rear pilot:

The ballast box can accommodate max. 4 weights of 2,4 kg mass (heavy weight) and 2 weights of 1,2 kg mass (light weight), so the max. mass is 12 kg.

The number of weights can be determined by the following table:

Mass of rear pilot		Number of trim weights	Number of blinks of the lamp in the front instrument panel see section 4.2.4
kg	lbs.		
55	121	2 heavy + 1 light	5
65	143	3 heavy	6
75	165	3 heavy + 1 light	7
85	187	4 heavy	8
95	209	4 heavy + 1 light	9
105	231	4 heavy + 2 light	10

Warning: When flying solo the ballast box must be emptied, except see b)! Otherwise you will fly with a dangerous C.G. position.

If the ballast box is filled up, the min. cockpit load in the front seat is raised by 35 kg (77 lbs.).

The resulting value (min. cockpit load in front seat from weighing without ballast + 35 kg) must be entered in the table on page 6.7 as value XX and also on the placard at the indication lights for the fin tank on the front instrument panel.

When using the trim weights make sure not to exceed the max. weight of 750kg (1653 lbs.) Category „U” or 630kg (1389 lbs.) Category „A“.

b) Trim-possibility for heavy pilots:

The ballast box may be used for this purpose too.

One trim weight of 1.2 kg raises the min. load in the front seat by 3.5 kg (7.7 lbs.).

One trim weight of 2.4 kg raises the min. load in the front seat by 7 kg (15.4 lbs.).

Example (1 kg= 2.2046 lbs):

Min. cockpit load of the glider:	70 kg	permissible amount of trim weights
Mass of the front pilot:	84 kg	2 x 2.4 kg
Mass of the rear pilot:	65 kg	3 x 2.4 kg or 2 x 2,4 kg and 2 x 1,2 kg
Total amount of trim ballast:		12 kg

This means that the ballast box can be filled completely for this example. Higher pilot masses can't be compensated.

Flight manual DG-1000T

6.8.8 Weighing report (for section 6.3)

Distances in mm, masses in kg -- 25.4 mm = 1 inch / 1 kg = 2.2046 lbs.

Date of weighing:					
Executed by:					
Date of equipment list:					
wing span	18m	20m			
Empty mass					
Empty mass C.G.					
Max. mass without W.B. Cat. U Cat. A	630	/			
Max. load without W.B. Cat. U Cat. A					
max. mass with WB					
max. useful load with W.B.					
min. cockpit load YY (kg)					
min. cockpit load XX (kg)					
min. cockpit load ZZ (kg)					
max. load in both seats	210	210			
Inspector, signature, stamp					

YY= ZZ + 16kg= min. load in front seat for solo flying with fin ballast box empty with fin battery.
 XX= YY+35= min. load in front seat for solo flying with fin ballast box filled with fin battery.
 ZZ= min. load in front seat for solo flying with fin ballast box empty and without fin battery.

Weighing was executed with: no battery in the fin
 tailwheel with: plastic hub
 brass hub (see section 0)

Flight manual DG-1000T

6.8.9 Empty weight C.G. limits (for 6.4)

x_S mm 1 mm=1 in./25.4, 1 kg= 2.2046 lbs

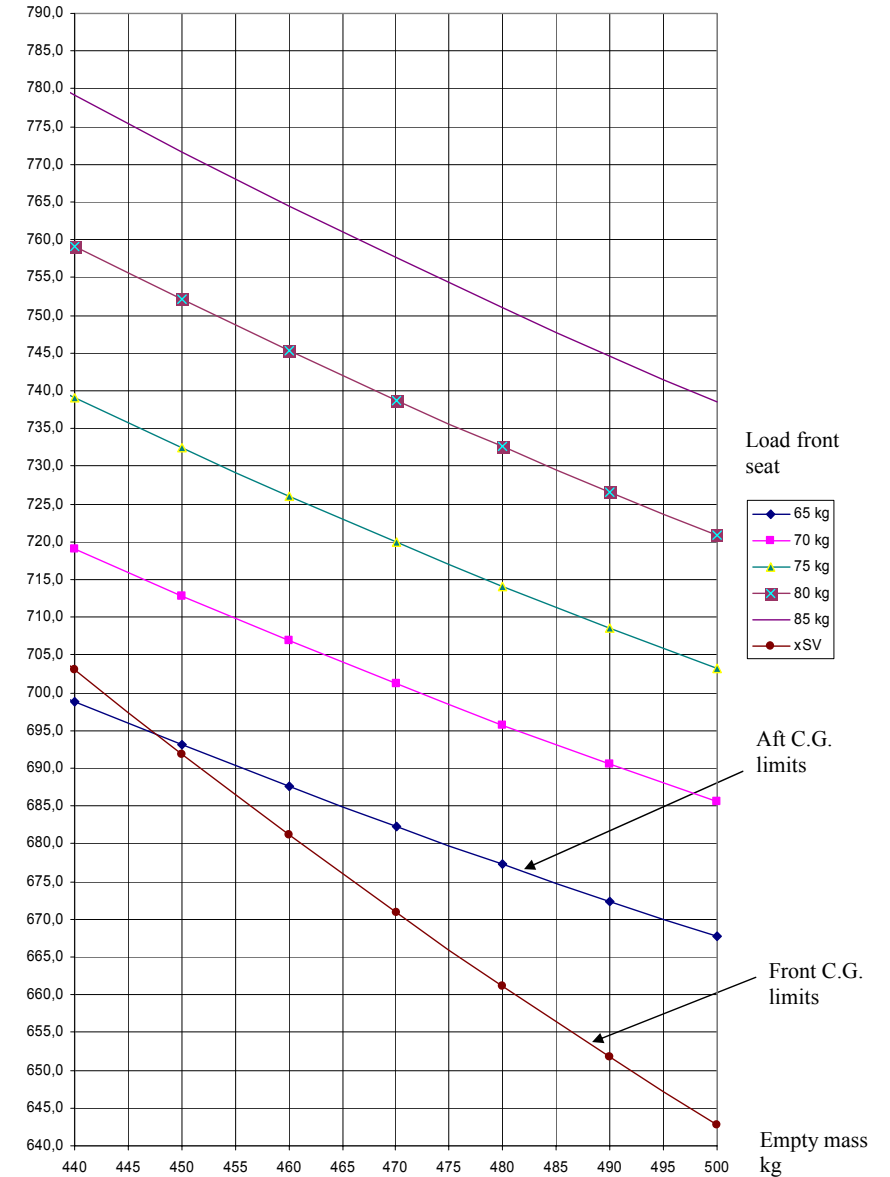

6.8.10 DG-1000 ballast chart (for 6.8.5)

To determine the max. allowable waterballast in the wing tanks for max. take-off weight 750kg

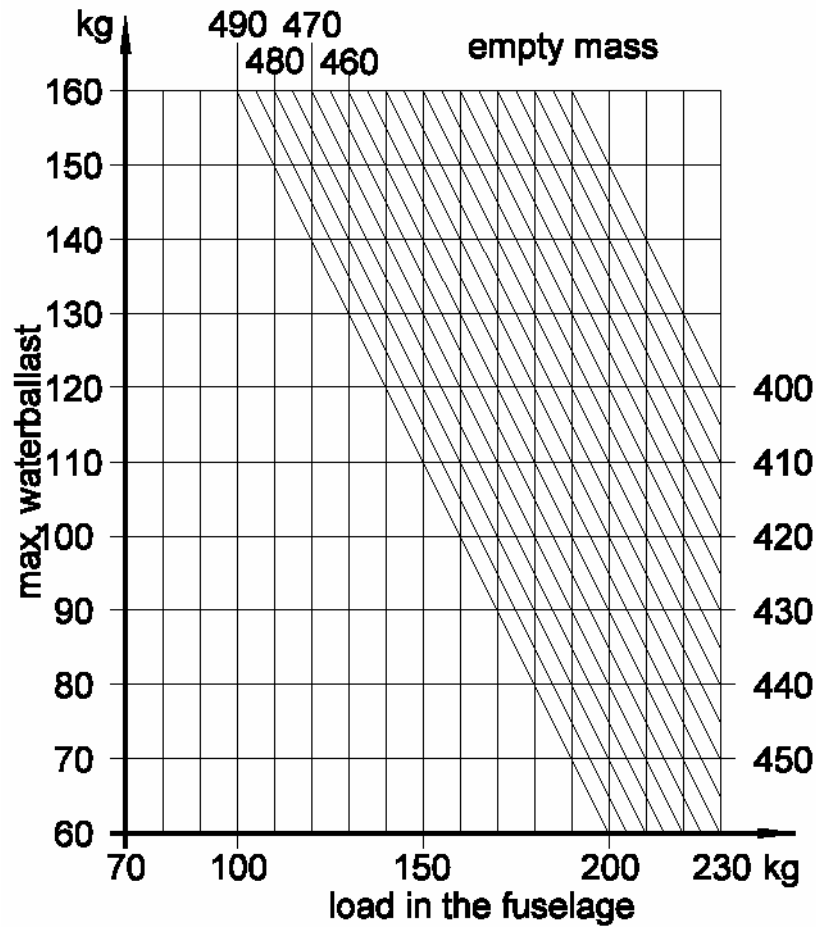

1 kg = 2.2046 lbs.
3.785 kg (l) = 1 US gal.

6.9 C.G. calculation

The actual C.G. can be determined as follows:

For each item, the moment mass x C.G. has to be determined and to be added up and divided by the total mass. See the following example:

1 kg = 2.2046 lbs. = .264 US gal. water 0.305 m = 1 ft

Item	mass [kg]	C.G. behind Datum [m]	Moment [m×kg]
Aircraft empty (with Battery in the fin)	480,0	0,710	340,80
Pilot front	75,0	-1,350	-101,25
Rear	85,0	-0,280	-23,80
Waterballast in the wings	80,0	0,206	16,48
Water in the fin tank	2,9	5,260	15,25
Ballast in box in the fin	9,6	5,400	51,84
Fuel	14,0	0,573	8,02
Total:	746,5	0,412	307,35

(X_S = Moment/Mass)

The limits of the in-flight C.G 0,200m - 0,440m should not be exceeded!

The most important C.G. positions (behind datum):

Pilot: The C.G. position is dependent on the pilots shape, mass and thickness of the parachute. The pilot C.G. position can be determined by executing a weight and balance measurement with glider empty and equipped with the pilot etc. see maintenance manual. Please note, that the distance a has to be measured with both configurations, as it may change due to deflection of the landing gear.

The pilot C.G. can be determined by the following equation:

$$X_P = (X_{SF} * M_F - X_{SE} * M_E) / M_P$$

M_F = flight mass X_{SF} = flight C.G M_P = pilot mass
M_E = empty mass X_{SE} = empty C.G.

7.1 Introduction

This section provides description and operating of the motorglider and its systems.

M.M. = Maintenance manual

Refer to section 9 "Supplements" for details of optional systems and equipment.

7.2 Airframe

The DG-1000T is a two-place high performance motorglider, either with 18 m span or with 20 m span and permanently installed winglets

Construction

Wings	CFRP-foam-sandwich-shell with CFRP-roving spar caps
Ailerons	CFRP-foam-sandwich-shell
Rudder	GFRP-foam sandwich-shell
Horizontal stabilizer	GFRP-foam sandwich-shell with CFRP-roving spar caps
Elevator	GFRP-shell
Fuselage	GFRP-shell, fuselage boom sandwich-shell with Tubus core

Canopy

Two canopies hinged at the right hand fuselage side. Canopy transparencies made from Plexiglas GS 241 or optionally green GS Green 2942.

Tailplane

T-Tail with conventional stabilizer-elevator and spring trim.

Colour

Airframe: white
 registration numbers: grey RAL 7001 (Pantone 444)
 or red RAL 3020 (Pantone 485)
 or blue RAL 5012 (Pantone 307)
 or green RAL 6001 (Pantone 349)

7.3 Cockpit, cockpit controls and placards

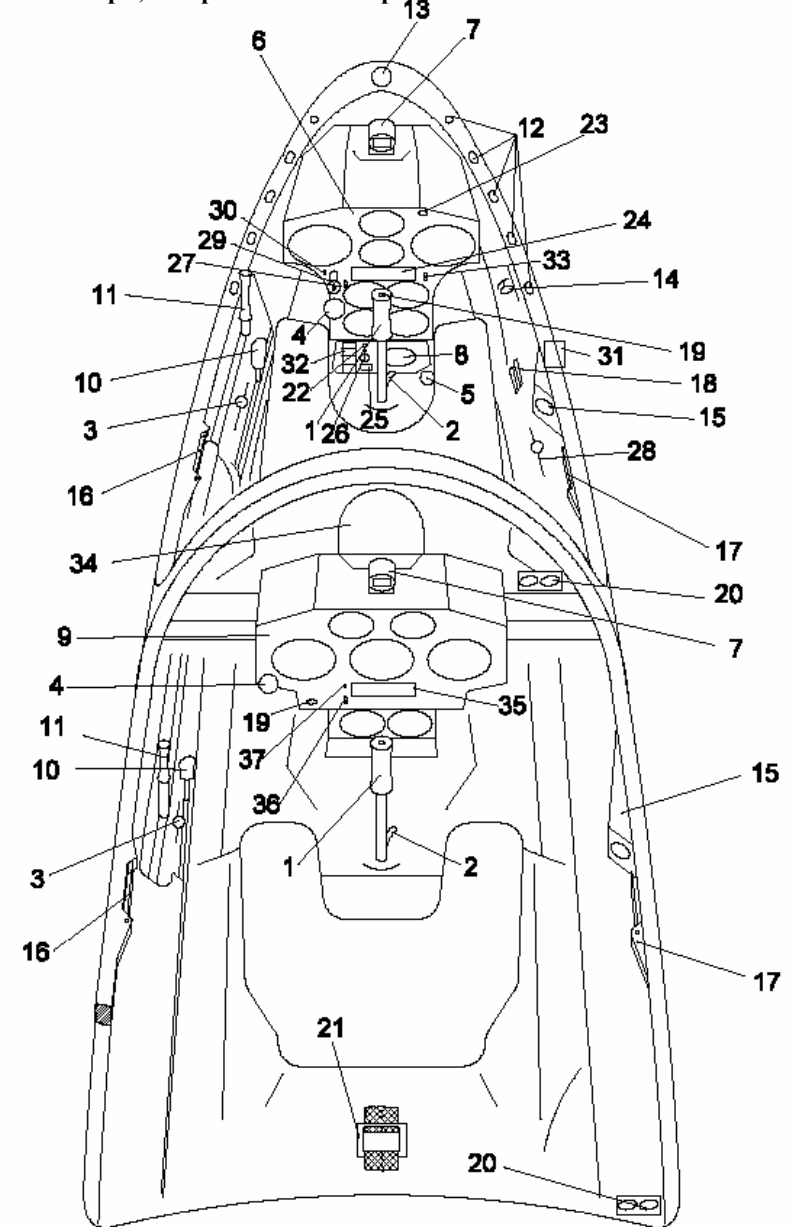

Flight manual DG-1000T

- 1) Control column
The rear control stick is removable. First open the snap shackle at the trim release lever to disengage the trim cable. Pull out the stick after unscrewing the cap nut.
- 2) Release lever for the trim mechanism - green
Operation see section 7.5 elevator control
- 3) Trim position indicator and trim preselection lever



- 4) Tow release knob - yellow



- 5) Rudder pedal adjustment knob – black
(only in front cockpit)



By pulling on the knob, the locking pin will be disengaged and the rudder pedals can be pulled back towards the pilot or pushed forward away from the pilot.

- 6) Front instrument panel
After removing the side screws at the base 2 x M 6 and after removing the screws attaching the cover to the panel 6 x M 4, the cover can be removed towards the front. The panel remains in the aircraft.
- 7) Compass installation position
- 8) Radio installation position
- 9) Rear instrument panel
After removing the side screws attaching the panel to the cover (4 x M 4) the panel can be hinged backwards into the cockpit (take out the control stick first!).

Flight manual DG-1000T

- 10) Undercarriage retraction - extension handle - black



back = retracted, front = extended,

The undercarriage is locked in the extended position by an overcentre locking arrangement and an additional safety catch. The handle is to be turned towards the cockpit wall, so that the locking catch will engage. In retracted position the landing gear is locked over centre.

With TN1000/13 executed, standard from ser. no. 10-133 on:

An additional landing gear positive locking device (notch and latch at the landing gear struts) secures the landing gear in the extended position. An additional catch in the front upper area of the landing gear box secures the landing gear in retracted position.

- 11) Airbrake handle - blue

The wheel brake is operated at the end of the airbrake handle travel.



Parking brake combined with an airbrake securing device (Piggott-hook): Pull the airbrake handle back to actuate the wheelbrake and rotate the handle to the cockpit wall. A detent will engage in one of 4 notches to hold the system in this position.

In case the airbrakes mistakenly haven't been locked, a detent engages in one of several notches to avoid inadvertent deployment of the airbrakes. To open and to close the airbrakes the operating handle must be rotated into the cockpit so far that the detent passes the notches.

- 12) Constantly open de-misting air vents
- 13) Main air vent
- 14) Main air vent operating knob
pushed to front = closed
pulled = open



- 15) Swivel air vents

- 16) Canopy opening handle - white-red
towards the nose = closed
into cockpit = open

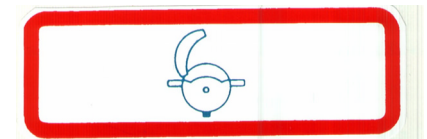

Flight manual DG-1000T

- 17) Canopy emergency release handle - red
towards the nose = closed
into cockpit = open

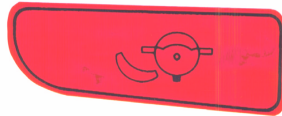

For emergency release also handle 16 has to be operated!

- 18) Water ballast dump handles - silver
lever on top of the handles = fin tank
Rotate backward to dump. The wing waterballast can only be dumped after dumping the fin waterballast
upper handle = right wing tank
lower handle = left wing tank
forward = valve closed
into the cockpit = valve open. The wing ballast can only be dumped after opening the fin tank



- 19) Push to talk button (Option) (placard only if installed in the instrument panel)

Senden
transmit

- 20) 12 V socket for charging the batteries and socket for headset (Option), front and rear cockpit..

- 21) Adjustment strap for the rear seat shell (to be operated on the ground)

- 22) Selector switch for additional batteries (Option),
up = internal battery
centre position = off
down = additional batteries

intern
off
extern

- 23) Control light for the trim ballast box in the fin:

The control light in the front instrument panel starts blinking after each transaction with the weights. By counting the amount of blinks, the amount of ballast can be determined. For a heavy weight 2 blinks appear and 1 blink for a light weight, this means 10 blinks if the box is filled up completely. After a pause of 2-3 seconds the blinking will be repeated etc.. The blinking can be stopped by pressing on the control light. Pressing again on the control light reactivates the blinking feature.

A switch will be operated by the locking pin of the ballast box cover.

As long as the switch is not closed, the control light for the ballast box will blink with doubled speed without interruption. The blinking can't be switched off by pressing on the control light.

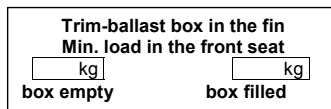

Flight manual DG-1000T

24. DEI-NT with integrated ignition switch: Switching up the ignition (the toggle has to be pulled out for switching). raises the powerplant to its operating position automatically
Switching off the ignition: First the powerplant will be retracted to the position for stopping the propeller from turning. the powerplant will remain in this position until the propeller stopped turning. Then the powerplant will be automatically retracted a further 5° and the propeller stopper moves forward in the propeller circle.
You may turn the propeller into the position for retraction (ignition switched off) by pressing the starter button.
As soon as the propeller is in the position for retraction (close to the stopper) the engine will retract by itself.
Description of the DEI-NT see section 7.4.

25. Socket for data download from the DEI-NT

26. Main switch (key switch)

Turn anticlockwise: off,

Turn clockwise first position: In this position the 12V

socket is live for charging the battery-

Turn clockwise second position: on

With this main switch the complete electric power supply will be cut off.

After taking out the main switch key the motorglider can't be operated.

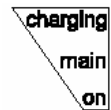

27. Manual retraction – extension switch for the powerplant

Any operation of this switch switches off the automatic

extension-retraction system (only with ignition switched off). Operation of the ignition switch reactivates the automatic system.

up = extension down = retraction.

Hold the switch until the extension procedure stops.

Note: Extend the engine manually on the ground prior to take-off or for maintenance work.

Manual retraction only to be used in the air if the automatics don't work.

Make sure, that the propeller is vertical.



28. Fuel cock – red
to the front = open
to the rear = closed

Close the fuel cock only in an emergency (see chapter 3)

zu Brandhahn auf
closed fuel cock open

29. Throttle handle with integrated starter button

Throttle

The starter button is only activated when the engine is extended and the ignition switch is in the "on" position.



Starter

With the engine running the starter motor will be blocked automatically.

Aligning the propeller for retraction with the starter button

If after stopping the propeller is not in the retraction position, it is possible to turn the propeller slowly with the starter motor into retraction position by pressing the starter button (ignition switched off). The starter motor speed is reduced by electronic means during this procedure. This procedure should not be used on the ground so as not to unnecessarily stress the starter motor.

30. **Primer switch**

up = automatic operation
down = off (no injection)



31. Rear view mirror to watch the propeller during aligning procedure

32. Circuit breakers

Circuit breaker for the electric variometer 2A
Circuit breaker for the radio 3A
Circuit breaker spare 3A
Circuit breaker spare 3A

Note: Further fuses are located in the control unit. Those are re-settable fuses.

33. Change over switch from static pressure to total energy pressure for the variometers (Option).

up **stat** = Variometers operating on static pressure= for powered flight
down **T E** = Variometers operating on total energy probe= soaring flight.

34. Head rest for front pilot

The headrest may be screwed to the rear cockpit instrument cover in different longitudinal positions.

35. DEI-NT in the rear cockpit (Option) with integrated ignition switch:
The ignition is only on and the powerplant will be extended, if the ignition switches in both cockpits are in the on position. As soon as 1 ignition switch will be switched off, the ignition is off and the powerplant will be retracted.

This means, that for operation from the front seat the ignition switch in the rear cockpit must be always in the "on" position. For operation from the rear seat, the ignition switch in the front cockpit must be "on".

Caution: For passenger flying etc. it is necessary to secure the ignition switch in the rear cockpit with the securing plate. The securing plate is equipped with a quarter turn lock which must be operated with a screw driver. For storage you may install the securing plate turned 90° in clockwise direction.

36. Manual powerplant extension-retraction switch in the rear cockpit (Option), only together with DEI-NT in the rear cockpit. 

37. Starter button in the rear cockpit (Option), only together with DEI-NT in the rear cockpit. 

38. **Throttle handle in rear cockpit TN1000/15 (Option):**

The handle is located between item 36) and 37), similar to the front cockpit (not shown in drawing on page 7.3).

Note: No starter button can be installed in the handle.

7.4 DEI-NT Operation

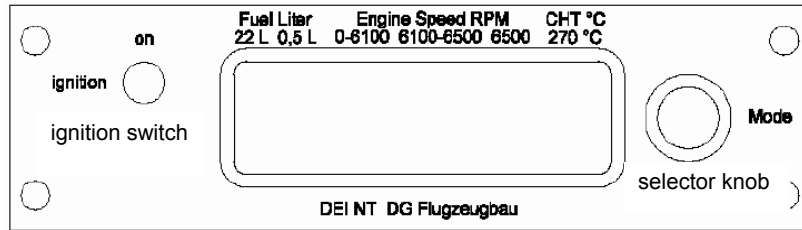

After turning on the main switch the DEI-NT shows a screen with operating times.

Then the screen changes to the gliding screen (powerplant retracted) or to the powered flight screen (powerplant not retracted).

You may change to other screens by pushing the selector knob (right hand side) until the DEI_NT beeps twice.

The following screens may be selected:

1. Gliding or powered flight (according to powerplant position)
2. Flight log
3. Operating times
4. Set up

Description of the screens:

Caution: In case of powerplant failures and if warnings are necessary full screen messages are displayed. All messages may be verified by a short push to the selector knob, the DEI-NT changes back to the normal screen.

7.4.1 Gliding and powered flight screens

Upper left: Fuel level: If the fuel level falls short of approx. 4 litres the message "Low Fuel" will be displayed,

DG-1000T: after verifying this message "R" is blinking.

DG-808C: after verifying this message the fuel level display is blinking, when reaching the amount of non useable fuel (0,4 litres) "R" starts blinking.

Lower left: Outside air temperature OA(T): When the OAT falls below 2°C the message "Water Freeze" will be displayed, after verifying this message the OAT display starts blinking.

Lower right: Battery voltage: Below a voltage of 11V the message "Low battery" will be displayed, after verifying this message the voltage display starts blinking. Above a voltage of 14,7V message "Battery Overch." will be displayed, after verifying this message the voltage display starts blinking.

Lower centre: engine time for this flight

7.4.1. a) Gliding screen

Upper centre: Stall factor, see set up menu.

Upper right: Time, instead of the CHT, will be displayed as long as the CHT is above 50°C.

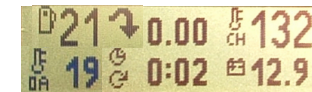

7.4.1. b) Powered flight screen

Upper centre:

- a) With the engine running the engine RPM will be displayed. When exceeding the max. continuous engine speed "Hi" will be displayed and is blinking at the left hand side of the RPM display..

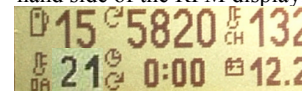

When exceeding the max. engine RPM the message "Engine Speed" will be displayed, the "Warning" symbol is blinking, after verifying this message the RPM display is blinking.

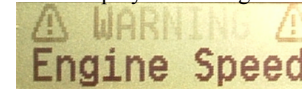

- b) As long as the engine is not running symbols showing the position of the powerplant will be displayed. If the powerplant is moving, in addition an arrow will be displayed showing if the powerplant is retracted or extended (not when moving the powerplant via the manual switch). As soon as the powerplant is completely retracted the screen changes to the gliding screen. .

In case the propeller is not in the position for retraction a short propeller side view will be displayed. In position for retraction a long propeller will be displayed.



powerplant extended
propeller in position for retraction



propeller not in position for retraction



powerplant in position for stopping the propeller



powerplant in position propeller stopper extended
propeller not in position for retraction



propeller in position for retraction

Flight manual DG-1000T

- c) When starting the engine a syringe symbol will be displayed (primer switch on auto position) whilst the primer valve is open.



If the engine will not accelerate when increasing throttle you may press the starter button again to activate the primer again. The syringe symbol will be displayed again.

- d) When moving the powerplant via the manual switch, a hand symbol will be displayed showing that the automatic extension-retraction function is deactivated. Operating the ignition switch will reactivate the automatic extension-retraction function. The hand will disappear.



Upper right: CH(T): Cylinder head temperature, above the max. certified CHT the message "CHT OverTemp" will be displayed, after verifying this message the CHT display is blinking.

Further messages (Failure messages and warning messages) see section 7.4.5.

7.4.2 Flight log

The following data will be displayed:

Date, take-off time, landing time, engine time of this flight.

With the selector knob you may choose a flight. by a short push to the selector knob further data for his flight will be displayed: flight duration, max. engine RPM, max. CHT, max. EGT (if sensors are installed).

DATE	START	LANDG	MOT	DURATION:	4:16
25.03	14:07	17:37	0:49	MAX. RPM:	6730
24.03	--:--	--:--	0:00	MAX. CHT:	237

7.4.3 Operating times

ENGINE TRIP: Trip counter for the engine time, reset in the Setup menu.

ENGINE TOTAL: Engine elapsed time counter, reset only by the manufacturer.

NEXT MAINTENAN.(ce) : The engine time until the next maintenance, reset in the Setup menu after completion of the 25 hour maintenance.

DEI Vx.x E-BOX Vx.x: Software versions of DEI-NT and control unit

ENGINE TRIP:	2:38
ENGINE TOTAL:	12:14
NEXT MAINTEN:	22:23
DEI V0.9 E-BOX	V1.2

Flight manual DG-1000T

7.4.4 Set up screen (menu)

On this screen 4 lines are displayed at a time, one of them is displayed negative and may be edited. Choose the line which is to be edited via the selector knob. Editing values: Push the selector knob, the DE-NT will beep once and the first value which may be edited will be displayed positive and may be altered via the selector knob. Push the selector knob to confirm this value and you get to the next value.

SET TIME:	12:16
SET DATE:	30.03.2005
STARTER SPEED	37%
PRIMER DOSE	99%

The following lines will be displayed:

RESET TRIP COUNTER: Push the selector knob, N (no) will be displayed, rotate the selector knob Y (yes) will be displayed, push the selector knob to reset the time to zero.

RESET MAINT. TIMER: Push the selector knob, N (no) will be displayed, rotate the selector knob Y (yes) will be displayed, push the selector knob to reset the time to the service-interval (25 hours).

FLIGHTLOG → PC: Push the selector knob, N (no) will be displayed, rotate the selector knob Y (yes) will be displayed, push the selector knob to reset start the download of the recorded data. The PC must be connected to the serial interface (socket close to the radio). You will download the flight log and service data see section 6.

SET TIME: Set up time

SET DATE: Set up date

STARTER SPEED: % of the normal starter motor power to turn the propeller into the position for retraction (ignition switched off) – standard value 35%, adjustable between 0-49%.

PRIMER DOSE: % of the max. amount of fuel injected by the primer, max. 99% - standard value 99%.

(With 0°C HT. the adjusted amount of fuel will be injected. The amount of fuel will be reduced linearly to 0 at 40° CHT).

PRIMER DURATION: Post starting injection of the primer, max. 99% of the time programmed in the control unit (40 seconds), standard value 99%

STALL FACTOR: With this factor the start of the stall warning will be set (warning via a buzzer or via a vibrator at the control stick (Option)).

Adjustment may be made by flying level and gently stalling the glider to determine the stalling speed, then fly approx. 5% faster, note the displayed stall factor (upper centre display) and change the factor in the set up menu to this value. You have to make the adjustment for one operating condition only.

The sensors for the stall warning make a quasi angle of attack measurement and thus the stall warning will work in other operating conditions too (different wing loading, turning flight, airbrakes extended etc.).

Flight manual DG-1000T

CAUTION: If the stall factor is set to 0.89 the stall warning is switched off completely. This setting is only allowed to eliminate a permanent stall warning in case a sensor fails. Send the DEI for repair to the manufacturer as soon as possible.

CALIBRATE FUEL G(auge): Calibration of the fuel gauge with empty tank. Push the selector knob, N will be displayed, rotate the selector knob, Y will be displayed. Push the selector knob to execute the calibration.

SYSTEM SETUP **:** Only for service by the manufacturer.

Push the selector knob until the DEI-NT beeps twice to leave the set-up screen.

FREEZE WARNING: Activation or deactivation of the warning message. You may deactivate this warning in case no watertanks are installed. When deactivated the OAT screen will still blink at low temperatures.

Push the selector knob, N will be displayed, rotate the selector knob, Y will be displayed, the FREEZE WARNING is activated. Rotate the selector knob N will be displayed, the FREEZE WARNING is deactivated. Push the selector knob to save this adjustment.

JOINT WARNING OUTP: Activation or deactivation of the signals (horn or the optional stick vibrator) to draw the pilots attention to the messages. Adjustment similar to Prop Brake.

Note: The signal for the stall warning will not be deactivated.

PRIMERTESTMODE: When you activate this mode the starter motor will be deactivated to enable testing the primer function see maintenance manual section 3.5.1 item 6.b). Adjustment similar to Prop Brake.

SWITCH-OFF WARNING: Activation or deactivation of the reminder to switch off the main switch. Adjustment similar to Prop Brake (from software version 1.7 on).

7.4.5 Display of powerplant failures and warnings

In case of powerplant failures and if warnings are necessary full screen messages are displayed. All messages may be verified by a short push of the selector knob, the DEI-NT changes back to the normal screen.

Powerplant failures:

Upper line displays "Failure" and is blinking, 2. line displays:

- "Engine Info" = no data transfer between DEI-NT and control unit
- "Spindle Fuse" = the fuse for the spindle drive is blown -> wait until it cools down and resets
- "RPM Pickup" = proximity switch defective -> automatic extension-retraction will be switched off
- "Primer Valve" = Primer-valve defective
- "OAT Sensor" = Outside air temperature sensor defective
- "CHT Sensor" = Cylinder head temperature Sensor defective
- "Fuel Sensor" = Fuel sensor defective

Flight manual DG-1000T

Warning messages:

Upper line displays "Warning " and is blinking, 2. line displays:

- "Canopy Open!" = rear canopy not locked
- "Spoiler" = airbrakes not locked, this warning is displayed only prior to and during take-off and will not be displayed when airbrakes are unlocked during the flight
- "Raise Gear" = Landing gear should be retracted, appears 4 minutes after take-off in case the landing gear is still extended
- "Landg. Gear " = Landing gear warning when airbrakes are unlocked and the landing gear is still retracted
- "Stall" = Stall warning appears simultaneously with the acoustically or tactile stall warning.
- "Low Battery" = Battery voltage permanently below 11V
- "Battery Overch." = Battery voltage permanently above 14,7V
- "Switch Error" = wrong sequencing of switches during powerplant extension -> automatic retraction will be switched off
- "CBox OvrTemp" = Starter motor control in control unit above temperature limit
- "CHT OverTemp" = CHT above max. certified value
- "Water Freeze" = OAT below +2°C
- "Low Fuel" = low fuel level
- "Engine Speed" = Engine RPM above max. certified value.
- "Starter Run" = Starter motor didn't disengage and produces electric power, stop the engine immediately to prevent damage of the electrical system. This message can't be deleted by pushing the selector knob.
- "Main Switch" = Reminder to switch off the main switch (from software version 1.7 on).

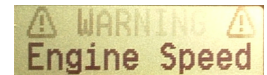

Explanation for failure messages

Spindle Fuse:

The re-settable fuse for the spindle drive may be blown in the following cases:

- a) The propeller hub hooks during extension at the engine doors.
- b) The limit switch in position engine extended or retracted is not operated.

As soon as the fuse is blown the Control Unit changes to manual extension-retraction mode and thus cuts off the electric power to the spindle drive and reports the failure to the DEI-NT.

After the cool-down time (approx. 10sec.) the message disappears and the symbol for manual operation (hand) will be displayed on the screen.

You may reactivate the automatic operation by operating the ignition switch, even during the cool-down time.

Case a) Retract the powerplant again manually, then try to extend the engine again..

Case b) Retract the engine manually a little and then try to extend the powerplant manually up to its operating position.

Flight manual DG-1000T

Switch Error: wrong consecution of switches during powerplant extension

If the DEI-NT has detected a wrong sequencing of the limit switches during powerplant extension, the powerplant will not be retracted automatically after stopping the engine, but the system switches over to manual operation and „Switch Error“ and the “hand” symbol will be displayed on the centre display. There is a possibility that the powerplant doesn't stop in the position where the propeller should stop turning and the still turning propeller hits the propeller stopper.

If the pilot can't detect any failure he may confirm the warning and reactivate the automatic retraction (switching the ignition on and off), but not before the propeller stops turning.

Error of the switch operated by the propeller-stopper, (no failure message)

It might be possible that the propeller stops just above the propeller stopper and presses on the stopper during powerplant retraction into the position where the stopper moves forward. The stopper can't move forward and operate the switch in this position.. To avoid any damage the powerplant will not retract completely. To accomplish this the DEI-NT checks within 3 seconds if the switch has been operated. If not, the powerplant will be extended automatically to the powerplant position where the propeller usually stops turning.

Rotate the propeller out of this position by pressing the starter button, further powerplant retraction is as normal.

Note: only in this special case is it possible to rotate the propeller with the starter motor in this powerplant position (position where the propeller usually should stop turning).

7.4.6 FLIGHTLOG → PC:

The following data may be downloaded:

Date, take-off time, landing time, flight duration, engine time, max. engine RPM, max. CHT, max. EGT (if sensors are installed) of each flight

The duration of the max. values of engine speed and CHT have been over the limits.

Failure of the CAN interface (data transfer from DEI-NT to control unit) resets of the DEI-NT

Over limit temperature of the control unit (hint for defects)

All messages and their confirmation

Download instructions can be found in the amendment to the maintenance manual.

Flight manual DG-1000T

7.4.7 DEI-NT in the rear cockpit (Option)

The DEI-NT in the rear cockpit is operated as a slave of the front DEI-NT. The functions and screens are similar to the front DEI-NT but no Flight log screen and no Set up screen and their functions are available. Instead of the failure message "Engine Info" a failure message “CAN Connect” will appear if there is no data transfer between DEI-NT and control unit or if the front DEI-NT is defective.

7.5 Flight controls

Rudder control

See diagram 2 M.M

Cable system with adjustable pedals in the front cockpit.

Elevator control

See diagram 1 M.M.

All pushrods slide in maintenance free nylon ball guides.

Automatic control hook-up system. Spring trimmer with release lever at the control stick and control knob at the left cockpit wall. To trim, you have to operate the release lever at the control stick and place the control knob to the desired position.

Aileron control

See diagram 3 and 4 M.M.

Pushrods slide in maintenance free nylon ball guides.

Automatic control hook-up system.

7.6 Airbrakes

See diagram 3 and 4 M.M.

Double storey Schempp-Hirth type airbrakes on the upper wing surface.

The wheel brake is operated by the airbrake system. Pushrods in the wings slide in maintenance free nylon ball guides. Automatic control hook-up system.

7.7 Landing gear

The DG-1000T is available with 3 different versions of the undercarriage:

- A) Very high, spring mounted, retractable main wheel with hydraulic disc brake, see diagram 7 M.M, tail wheel.
- B) High spring mounted retractable main wheel with hydraulic disc brake, see diagram 8 M.M, tail and nose wheel
- C) Spring mounted, fixed main wheel with disc brake, see diagram 9 M.M., tail and nose wheel.

The main undercarriages versions B and C are interchangeable.

a) **Main wheel:**

retractable, assisted by a gas strut (locked in retracted position by an overcentre locking device) or non retractable.

Spring mounted with steel compression springs, fully sealed landing gear box,.

Tyre: 380 x 150 6 PR, diameter 380 mm (15 in.),

Wheel: Tost 5" wheel with disc brake, width 134 mm, axle 30 mm

Tyre pressure: 2,5 bar (36 psi)

b) **Tail wheel:**

Tyre 200 x 50 6 PR, diameter 200 mm (7,87in.)

Wheel: Plastic hub with ball bearings, part. No. S23

Tyre pressure 4 bar (58 psi)

c) **Nose wheel** (only version B) and C):

Tyre: 260 x 85, diameter 260 mm (10,2 in)

Wheel: Tost 4" wheel, width 85 mm, axle 20 mm

Tyre pressure: 2,5 bar (36 psi)

7.8 Tow hooks

See diagram 5 M.M.

Safety release "Europa G 88" for winch launch installed near the C.G.

"nose release E 85" installed in the fuselage nose for aerotow.

Both hooks are operated by the same handles.

7.9 Seats and safety harness

The front seat is constructed as an integral inner shell.

The rear seat is height adjustable. The adjustment is by means of a strap similar to the shoulder harness.

As safety harness only symmetric 4-point harnesses fixed at the given fixing points are allowed.

7.10 Baggage compartment

Max. load 15 kg (33 lbs.).

Heavy pieces of baggage must be secured to the floor.

7.11 Waterballast system

(Optional with 18m wingspan, standard with 20m wingspan)

See diagram 6 M.M.

The **wingtanks** are constructed as double wall bags with a capacity of 80 l per wing. The dump valves are mounted in the wings and the control is hooked up automatically when rigging the glider.

Fin ballast tank

Ballast to compensate the mass of the water ballast in the wings, max. 6,2 kg. This tank is an integral tank with a dump hose, an overflow and a ventilation line. The ventilation line ends in the fin trailing edge shear web, the dump hose and the overflow line are ending at the rear end of the fuselage besides the lower rudder mount.

Filling is via the dump hose. The dump valve is opened by a cable and closed by a steel tension spring.

Control handles

The handle for the fintank (wide plate) is above the wingtank handles, so that the wingtanks can only be emptied after opening the fintank.

Warning: It is prohibited to change this system!

The handle for the fintank will stay in the open position by an overcentre device. The upper handle is for the right and the lower handle for the left wingtank.

7.12 Ballast box in the fin

A box for ballast (trim-weights) is installed in the fin. It can be used to compensate the mass of the rear pilot and as a trim-possibility for heavy pilots. Max. ballast capacity: 12 kg.

Filling see section 4.2.4, determination of the permissible amount of ballast see section 6.8.7.

Indication of the amount of ballast inserted is via a control light in the front instrument panel see section 4.2.4 and section 7.3 item 23).

7.13 Powerplant

7.13.1 Engine and propeller

See section 2.4.

7.13.2 Extension - retraction mechanism

Electric spindle drive assisted by a gas-strut.

The opening and closing of the engine bay doors is automatic.

Fuselage tank

22 l (5.81 US gal.) (useable amount of fuel). A condensator type probe is installed in the tank to allow an indication which is almost independent from the pitch angle.

A switch located at the lower end of the tank filler cuts off the electric power for the electric refuelling pump as soon as the tank is full.

Fuel pump

Electric pump, controlled via the ignition switch, installed in the fuselage centre section.

In line to the pump described above, a second mechanical pump is installed. This pump is driven by the engine's suction pulses and thus operates only with engine running.

A refuelling pump with connector and operating switch is installed in the engine compartment (left front).

7.14 Electrical system

7.14.1 On-board battery

A sealed maintenance free battery 12V/17Ah is installed in the engine compartment (left front).

A fuse (60A) is installed in the positive wire close to the battery.

The engine is not equipped with a Generator to charge the battery.

Recharging the battery with an automatic battery charger is possible via the 12 V sockets in both cockpits. Therefore the master switch must be in the first "charging" position.

7.14.2 Battery in the baggage compartment (Option)

See section 7.17.5

7.14.3 Battery in the fin

see section 7.17.6

Warning: Use only automatic chargers designed to charge sealed lead acid batteries. To charge the battery to its full capacity a charger with 14.4 V max. charging voltage is necessary (normal automatic chargers charge only up to 13.8V). Such a charger is available from DG Flugzeugbau code no. Z 08.

7.14.4 Wiring

All current - carrying wiring confirms to aeronautical specifications.

7.14.5 Powerplant control and fuses

The DEI-NT (digital engine indicator) and its control unit controls all automatic and safety functions and displays the engine indications on digital displays. The control unit incorporates the master switch, the starter relay, extension-retraction relays and fuses.

7.15 Pitot and static system

see diagram 8 M.M.

Pitot probe in fuselage nose, static ports a short distance behind fuselage nose. The airspeed indicator and the altimeter are to be connected to these ports and probe.

Probe (PC) for the stall warning device below the fuselage nose.

Additional holder for a TE-probe or a Multiprobe in the fin is to operate variometer and flight computer systems. To preserve the sealings inside the holder, the end of the probe should be greased with e.g. Vaseline from time to time.

7.16 Canopies

To **jettison** the canopies in flight see section 3.2.

Removing a canopy:

Open the canopy, detach the restraining cable and if installed detach the gas strut from the front canopy. Then close the canopy and operate the red canopy emergency release handle (right) and the white-red canopy opening handle (left). Lift the canopy upwards.

Reinstalling a canopy:

Open emergency release and canopy locking levers. Place the canopy in vertical direction onto the fuselage. Close the emergency release. Open the canopy and snap in the retaining cable and the gas-strut (if installed).

Checking the canopy emergency release system:

- a) check with open front canopy if the gas-struts (if installed) can be disengaged from their ball fittings (from canopy and from fuselage). Grease the ball fittings.
- b) check with closed canopy if the emergency release handle can be operated and if the canopy can be removed easily, resp. if the canopy will be lifted by the gas-strut. Grease the locking pins.

7.17 Miscellaneous equipment (Options)

7.17.1 Removable ballast for under weight pilots

The ballast boxes (Option) at the right and left hand side of the instrument console underneath the carpets can accommodate 2 ballast weights of min 2.4 kg (5.3 lbs.) each. Each weight compensates a pilot mass of 3.2 kg (7 lbs.). So a max. of 12.8 kg (28 lbs.) missing pilot mass can be compensated.

The ballast weights are to be fixed in the box with a M8 knurled nut.

Note: The ballast weights used for the ballast box in the fin may be used for these ballast boxes too.

7.17.2 Oxygen system

- a) Installation of the oxygen cylinders

Max. size of oxygen bottle is 7 l capacity with diameter 140 mm (5.5 in.)- If a bottle with smaller diameter is used, this bottle must be wrapped with plastic to come to the same diameter of 140 mm. The bottle must be fixed at its neck with a bracket Z 14 (available at DG-Flugzeugbau GmbH).

- b) Installation of the oxygen equipment

To ensure a safe installation ask DG Flugzeugbau for an installation instruction. For the installation of the Dräger Höhenatmer E 20088 you will find an installation plan 5EP34 in the maintenance Manual.

7.17.3 ELT Emergency Locator Transmitter and Transponder

Installation see maintenance manual DG-1000S section 6.

Caution: Concerning 7.17.2 and 7.17.3.

The installation has to be accomplished by DG-Flugzeugbau or by an approved service station and to be inspected and entered in the aircraft log book by a licensed inspector.

7.17.4 Heavy tailwheel

Instead of the standard tailwheel with plastic hub S23 a tailwheel with brass hub S27/1 may be installed. The installation kit S27/4 is available at DG Flugzeugbau.

The difference in mass between both hubs is 3.1 kg (6.84 lbs.). With the brass hub the min. front cockpit load is increased by 8.5 kg (18.74 lbs.). This higher value must be entered in the cockpit data placards and on page 6.7. Even if the heavy tailwheel is installed only sometimes, the higher min. cockpit load must be entered.

7.17.5 Battery in the baggage compartment with battery selector switch

An additional battery Z01 may be installed in the baggage compartment. In this case a battery selector switch must be installed in the front instrument panel.

Selector positions:

up = internal battery centre position = off down = additional batteries

Preferably the gliding computers and loggers shall be connected to this switch.

The battery fuse is installed at the battery, type: G fuse 250 V 5 x 25 medium slow / 4 A.

7.17.6 Battery in the fin

A battery may be installed in the fin.

Section 0 and the loading chart see section 6.8.4 must be regarded.

Only the use of the factory supplied battery Z110 (12 V, min. 12 Ah, mass 5.5 kg, 12.1 lbs.) is permitted.

The battery fuse is installed at the battery, type: G fuse 250 V with indicator 5 x 25 medium slow / 4 A.

The wiring for this battery is in parallel to the battery in the baggage compartment

7.17.7 Radio installation with automatic commutation

If the factory approved radio installation set is installed, the radio will be switched automatically from "normal" mode to "engine on" mode with the engine extended. With "normal mode" only the goose neck microphones are working.

With "engine on" mode the intercom system is working. Only the microphones of the headsets are working.

The loudspeaker and the speakers of the headsets are working together in both modes.

8 Motorglider handling, care and maintenance

Section	Page
8.1 Introduction.....	8.2
8.2 Inspection period, maintenance	8.2
8.3 Alterations or repairs.....	8.3
8.4 Tie Down, Parking	8.3
8.5 Transport	8.4
8.6 Towing on the ground.....	8.4
8.7 Cleaning and Care.....	8.5

Flight manual DG-1000T

8.1 Introduction

This section contains manufacturer's recommended procedures for proper ground handling and servicing of the motorglider. It also identifies certain inspection and maintenance requirements which must be followed if the motorglider is to retain that new-plane performance and dependability. It is wise to follow a planned schedule of lubrication and preventive maintenance based on climatic and flying conditions encountered.

8.2 Inspection period, maintenance

The "Instructions for continued airworthiness" (maintenance manual) for the DG-1000T have to be followed.

- A Before each rigging all the connecting pins and bushes should be cleaned and greased. This includes the control connectors.
- B The contact surfaces of the canopies to the fuselage are to be rubbed with colourless floor-polish (canopy and fuselage side) to reduce grating noise in flight. Polish at the beginning of the flight season and then every month.
- C Once a year all the bearings and hinges should be cleaned and greased. See the greasing programme of the maintenance manual.
Each year the control surface displacements, adjustments and general condition must be checked. (See the maintenance manual).

Flight manual DG-1000T

8.3 Alterations or repairs

It is essential that the responsible airworthiness authority be contacted prior to any alterations on the aeroplane, to ensure that the airworthiness of the motorglider is not impaired. It is prohibited to execute the alteration without the approval of the airworthiness authority. The manufacturer will not be liable for the alteration or for damages resulting from changes in the characteristics of the aircraft due to alteration. So it is strongly recommended to execute no alternatives which are not approved by the aircraft manufacturer.

External loads such as external camera installations are to be regarded as alterations! Repair instructions can be found in the DG-1000T repair manual. No repairs should be carried out without referring to the manual.

8.4 Tie Down, Parking

Use textile ropes or straps to tie down the wing tips. The fuselage should be tied down just ahead of the fin.

Water ballast can be left in the wings for a few days only, but not when there is the possibility of freezing! On sunny days the cockpit should be closed and covered.

Note: Longer parking with exposure to sun and humidity will cause premature ageing of the external surfaces of your motorglider.

8.5 Transport

It is recommended to carry this valuable motorglider in a factory approved closed trailer.

Approved fitting points:

Inner wing panels:

- Wing spar as close to wing rootrib as possible or a rootrib wing cradle.
- A wing cradle at the taper change.

Horizontal tailplane and outboard wing panel:

- Cradles as desired

Fuselage:

- A felt lined fibreglass nose cap which does not extend over the canopy, secured to floor.
- Fuselage dolly in front of the undercarriage
- Tail wheel-well in trailer floor. Secure fuselage with a belt in front of the fin or hold it down with the trailer top (soft foam in top).

All aircraft structures should not be subject to any unusual loads. With high temperatures that can occur inside trailers, these loads in time can warp any fibre reinforced plastic motorglider.

The trailer should be well ventilated so as to prevent moisture build up which could result in bubbles forming in the gelcoat. A solar powered ventilator is recommended.

8.6 Towing on the ground

- a) by towing from the nose hook using a rope with the standard double ring approved for the release
- b) by using a tow bar which is fixed at the tail dolly and a wing tip wheel.

The tow bar and wing tip wheel and the tail dolly may be ordered through the DG Flugzeugbau factory.

8.7 Cleaning and Care

Exterior surfaces of the fibre-reinforced plastic parts

The surfaces are coated by a UP-gelcoat or Polyurethane paint (Option). This surface is protected by a hard wax coating which has been applied during production with a rotating disc ("Schwabbel" procedure). Do not remove the wax, because this would lead to shading, swelling and cracking of the surface. In general, the wax coat is very resistant. As soon as the wax coat is damaged or worn, a new coat has to be applied (see maintenance manual sect. 3.1). If you store your aircraft often outside, this may be necessary every half year!

Hints for care

- Wash the surface only with clean water using a sponge and chamois.
- The adhesive remains of tape may be removed with petroleum ether (pure petroleum spirit) which should be applied and removed immediately, otherwise this may lead to swelling of the gelcoat.
- More stubborn dirt which cannot be removed by washing may be cleaned off with silicone-free, wax containing car polishes (e.g. 1Z Extra, Meguiars in USA).
- Long-term dirt and shading can be removed by applying a new hard wax coat (see maintenance manual sect. 3.1).
- Never use alcohol, acetone, thinner etc.. Do not use detergents for washing!
- Protect the surface from intense sunlight.
- Protect the aircraft from water and moisture. See sections 8.4 and 8.5.
- Remove water that has entered and allow the aircraft to dry out.
- Never store your wet aircraft in a trailer.

Flight manual DG-1000T

Plexiglas canopy

- Use clean water and a chamois for cleaning.
- Stubborn dirt and small scratches can be removed by use of the "Schwabbel procedure" (see maintenance manual sect. 3.1).

Metal parts

- The pins and bushes for rigging the aircraft are not surface protected and must be covered with grease at all times.
- The other metal parts, especially the control stick and all handles should occasionally be preserved with metal polishes.

Flight manual DG-1000T

9 Supplements

Section		page
9.1	Introduction	9.2
9.2	List of inserted supplements	9.2
9.3	Electrically operated main landing gear	9.3 – 9.12
9.4	Special equipment for very small pilots	9.13

9.1 Introduction

This section contains the appropriate supplements necessary to safely and efficiently operate the sailplane when equipped with various optional systems and equipment not provided with the standard sailplane.

9.2 List of inserted supplements

Date of insertion	Document No.	Title of the inserted supplement
November 2008	Section 9.3	Electrically operated main landing gear TN1000/14
May 2010	Section 9.4	Special equipment for very small pilots TN1000/17

9.3 Electrically operated main landing gear

Introduction

In the following text the changes to those sections of the flight manual which are affected by the installation of the electrically operated main landing gear will be given

Section 1 General

1.4 Descriptive data

Subsection amended

With landing gear version A) the main landing gear may be operated electrically as an option, Version D).

D) Very high, spring mounted, electrically operated retractable main landing gear, wheel with hydraulic disc brake, tail wheel

With this version there are no handles and control rods for manual operation of the landing gear like Version A.

A landing gear warning device is integrated into the system.

Both cockpits are equipped with all controls and control lights

A manually operated emergency extension system is provided.

Technical data:

Extension and retraction time (electrically operated): approx. 7seconds

Extension time emergency operation: approx. 2 seconds

Section 2 Limitations

subsections amended

2.2 Airspeed

Note: VLO is not changed compared to the manually operated main landing gears

	Speed	IAS km/h (kts.)	Remarks
VLO	Maximum landing gear operating speed	185 (100)	Do not extend or retract the landing gear above this speed.
VLE	Never exceed speed in case the landing gear is not locked	150 (81)	Do not exceed this speed in case the landing gear is not locked, see emergency procedures sect. 3.20

Warning: If the landing gear is operated at speeds higher than VLO and if gusts generate accelerations higher than 4 g the landing gear may be damaged.

2.9 Approved manoeuvres

No aerobatic manoeuvres are allowed during extension and retraction of the landing gear and in case you fly with the landing gear unlocked (see emergency procedures sect. 3.20).

2.10 Manoeuvring load factors

	max. speed	g-load
operating the landing gear	VLO	+4 -2,65
in case the landing gear is not locked	VLE	+4 -2,65

2.21 Limitation placards

Below the controls and control lights for the electrically operated landing gear see sect. 7.3:

LG ext.-retr. up to 185 km/h 100 kts.
--

Section 3 Emergency procedures

new subsection

3.19 Emergency extension of the electrically operated main landing gear

If extending the landing gear via the electrical system is not possible, the landing gear may be extended manually. The extension force is produced by a gas strut. For emergency extension pull on one of the 2 black-red emergency extension handles (located at the left hand fuselage wall, one in each cockpit), pull the handle until the landing gear is fully extended. The travel is about 15 mm (.6 in.), the extension time about 2 seconds. During extension the centre (red) LED is shining. When the landing gear is fully extended the lower green LED also starts shining.

Warning: Don't let the handle go before the green LED starts shining. If you don't pull for long enough the landing gear will rest in a position not locked over centre and will be destroyed at touch down.

Caution: If you execute the emergency extension at high airspeed it may take a longer time until the landing gear is fully extended. You should shorten the time by reducing the airspeed.

Caution: If emergency extension was necessary check the system to detect the failure and repair the system.

Resetting the system for normal operation see section 4.5.12.3.

3.20 Incompletely retracted electrically operated main landing gear

If the landing gear is not locked the centre (red LED) starts blinking approx. 22 seconds after the start of the retraction.

In this condition the retraction mechanism may be damaged with g-loads exceeding 4 g.

Instruction 1: Extend and retract the landing gear again.

Instruction 2: If instruction 1 was not successful extend the landing gear and land as soon as possible to fix the problem. For the remainder of the flight, don't fly faster than 150 km/h (81 kts.) and avoid abrupt manoeuvres.

Section 4 Normal procedures

4.2 Rigging and derigging

new subsection

4.2.8 Extension and retraction of the electrically operated main landing gear

Extension see 4.5.12.1 normal procedures

Warning: The main landing gear can only take up the weight of the glider when fully extended and locked. Therefore it is essential that during extension of the landing gear no load is applied to the main wheel. Lift the trailer ramp high enough. If there is a risk that the ramp may come down while the landing gear is extending secure the ramp, e.g. with blocks.

If such a case happens nevertheless switch the landing gear to retraction. To accomplish this you must switch up and hold the toggle switch and press the press button simultaneously 3 times within 2 seconds.

Warning: If you operate the retraction or extension the landing gear will travel to the up or down stop. So make sure that there are no obstacles which may be caught by the landing gear to prevent damage or injuries.

You can stop the travelling by switching the toggle switch in the reverse direction and pressing the press button simultaneously

4.5 Normal procedures

new subsection

4.5.12 Electrically operated main landing gear

4.5.12.1 Extension and retraction in flight

Retraction: For retraction switch and hold the toggle switch up and press the press button twice within 2 seconds. With each press on the button a signal will sound. The landing gear will retract automatically. You may let go of the switches. During retraction the centre (red) LED will shine and the upper green LED will blink. As soon as the landing gear is retracted and locked only the upper green LED will shine.

Warning: If the upper green LED doesn't start to shine and the red LED instead starts blinking refer to section 3.20 emergency procedures.

Extension: For extension switch the toggle switch down and let go.. The landing gear will be extended and locked.

During extension the centre (red) LED will shine and the lower green LED will blink. As soon as the landing gear is extended and locked only the lower green LED will shine.

Note: In case of high acceleration during extension or retraction an over current cut off system will switch off the spindle drive to protect the system. As soon as the g-loads decrease, the landing gear will continue to travel.

Note: To save electrical power during flight the upper green LED will stop shining after approx. 5 minutes, landing gear retracted and locked.

4.5.11.2 Extending the landing gear via the emergency extension system.

The emergency extension system is also designed to be operated for in flight training purposes. Operation see section 3.19.

Resetting the system for normal operation should be executed after landing, for procedure see section 4.5.12.3.

Caution: It is strongly recommended to train the emergency extension in flight.

Note: Resetting the system for normal operation is also possible in flight.

However, this is only permissible if there are 2 pilots on board, one pilot flying the glider and the other resetting the system.

Then you may retract the landing gear again according to section 4.5.12.1. to continue the flight.

4.5.12.3 Resetting the emergency extension system for normal operation

After an emergency extension the system must be reset for normal operation. To accomplish this you must pull one of the 2 emergency extension handles and simultaneously switch the toggle switch down. The centre (red) and the lower green LED will shine.

Switch and handle must be operated until the centre LED stops shining and only the lower green LED continues shining. The spindle drive will then stop operating, then let go handle and switch

Thereafter you may retract the landing gear again according to section 4.5.12.1.

4.5.12.4 Part extension and retraction for inspection and servicing

The retraction may be stopped by switching the toggle switch down, The extension may be stopped by switching the toggle switch up and pressing simultaneously the press button.

Only the red LED will shine.

For any service work switch off the main switch!

With the procedures described in section 4.5.12.1 you may retract or extend the landing gear again.

4.5.12.5 Precautionary measures against retracting the landing gear while on the ground

If the glider is resting on the main landing gear the landing gear should not be retracted, as retraction will result in damage of the landing gear. To minimise the risk of such operating error the following safety features have been incorporated:

1. If the toggle switch is switched up, nothing will happen.
2. If the toggle switch is switched up and the press button is pressed 1 time a warning tone will sound, otherwise, nothing will happen.
3. Only if the toggle switch is switched up and the press button is pressed 2 times within 2 seconds the landing gear will be retracted.

Caution: If you leave the DG-1000 unattended switch off the main switch to prevent any operating error.

Section 7 Sailplane and system description

7.3 Cockpit, cockpit controls and placards

Subsection amended

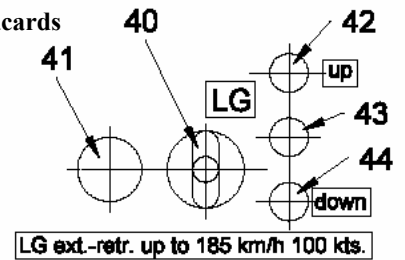

Controls and control lights for the electrically operated landing gear in front and rear instrument panel (upper left hand side):

- 40) Toggle switch for extension and retraction of the electrically operated main landing gear
up retracted and locked
down extended and locked over centre
- 41) Press button for retraction of the electrically operated main landing gear
 For retraction switch and hold the toggle switch up and press the press button 2 times within 2 seconds.

42) – 44) control lights (LED's) for the electrically operated main landing gear:

Condition	control light indication
Normal operation	
LG retracted and locked	42) upper green shines
LG extended and locked	44) lower green shines
LG retracting	43) red shines, 42) upper green blinking
LG extending	43) red shines, 44) lower green blinking
LG stopped in intermediate position	43) red shines
Emergency operation	
LG extends	43) red shines
LG extended and locked	44) lower green shines, 43) red shines
System resetting	44) lower green shines, 43) red shines
Failure messages	
Time overflow: Signal appears if within 22 seconds after start of the travelling no limit switch activates	43) red blinking + upper or lower green blinking according to travel direction
One limit switch defective	all LED's blinking

Note: To save electrical power during flight the upper green LED will stop shining after approx. 5 minutes if the landing gear is retracted and locked.

Flight manual DG-1000T

45) Landing gear emergency extension handles black-red
The handles are located at the left hand fuselage wall, one in each cockpit at the positions of the handles for the manually operated landing gears, item 10).



For emergency extension pull on one of the 2 red emergency extension handles, pull the handle until the landing gear is fully extended.

Note: 26) Control light for the trim ballast box in the fin may not be installed at the position shown in the sketch on page 7.3 but at another suitable place in the front instrument panel.

Flight manual DG-1000T

7.7 Landing gear

Subsection amended

D) Very high, spring mounted, electrically operated retractable main landing gear, wheel with hydraulic disc brake, see diagrams 20 and 21 M.M, tail wheel
With this version there are no handles and control rods for manual operation of the landing gear like Version A.

In the normal operating mode the landing gear will be retracted and extended by an electrical spindle drive.

A control unit which is installed in the rear instrument tower controls all electrical functions and the control lights.

A landing gear warning device is integrated into the system.

Both cockpits are equipped with all controls and control lights

The landing gear will be locked in the extended position by over centre locking of the drag struts.

The landing gear will be locked in the retracted position by 2 latches.

The system is equipped with a safety circuit against retraction of the landing gear on the ground see section 4.5.12.5.

The system is equipped with an over current cut off which stops the extension or retraction if high accelerations occur to protect the drive against damage. As soon as the g-loads lower, the landing gear will continue to travel.

Emergency operation: If the electrical system is damaged or no battery power is available, the landing gear may be extended manually. The handles are located at the left hand fuselage wall, one in each cockpit at the positions of the handles for the manually operated landing gears).

Pulling on one of the 2 red emergency extension handles will open the valve of a lockable gas strut. The gas strut will push the spindle drive forward on a linear guide to extend and lock the landing gear.

Technical data:

Extension and retraction time (electrically operated): approx. 7seconds

Extension time emergency operation: approx. 2s

Power: 12V, max. 10 A

7.14 Electrical system

Subsection amended

Electrical system with electrically operated landing gear

Wiring see wiring plan 10E4 enclosed to the maintenance manual.

Fuses:

The electrically operated landing gear is protected by an automatically reset fuse in the landing gear control unit.

Landing gear warning:

A landing gear warning device is integrated into the system. Warning is by a buzzer and in addition via the . DEI-NT see section 7.4.5.

9.4 Special equipment for very small pilots (TN1000/17)

To facilitate the operation of the glider by very small pilots 3 different items have been developed, which may be used separately or together.

9.4.1 Removable seat back for the front seat

- a) Installation of the seat back: Install the seat back with 2 screws M6x16 DIN965 4.8 BIC with cup washers 15 x M6 MS NI NR4157 to the threads which have been installed according to working instruction No. 1 for TN1000/17.
- b) The seat back may be adjusted further to the front by part Z198. Fix the part to the Velcro straps installed at the rear of the seat back.
- c) DG-1000 from ser. no. 10-19 on: Remove the headcushion 8R80/2 from the holder on the rear instrument panel cover (fixed with Velcro). When removing the seat back reinstall the head cushion at the holder. Install the head cushion see above to the Velcro straps installed at the front of the seat back. Instead of the approx. 70 mm (2.8 in.) thick head cushion a thinner head cushion approx. 40 mm (1.6 in.) thick may be used.
- d) DG-1000 up to ser. no. 10-18: Remove the head rest from the seat (screwed connection). When removing the seat back reinstall the headrest. Install a head cushion 8R80/4 to the Velcro straps installed at the front of the seat back.

9.4.2 Airbrake-pushrod with additional handle in front cockpit

For pilots with arms too short to lock the airbrakes an airbrake-pushrod with additional handle part 5St69/2 may be instead in the front cockpit according to working instruction No. 2 for TN1000/17 instead of part 5St69. This part may remain in the glider for normal operation.

9.4.3 Rudder pedal plates for rear cockpit Z197

Pilots with very short legs may clip rudder pedal plates part no. Z197 on to the rudder pedals. Plates may be installed and removed as often as desired.