

DG Flugzeugbau GmbH

Otto-Lilienthal-Weg 2 / Am Flugplatz • D-76646 Bruchsal • Germany

Postbox 1480, D-76604 Bruchsal • Germany

Tel. 07251 3020-0 • Telefax 07251 3020-200 •

E-mail: dg@dg-flugzeugbau.de

Spare part and material sales: Tel. 07251 3020-270 •

E-mail: lager@dg-flugzeugbau.de

www.dg-flugzeugbau.de

Manual for the emergency bail out aid NOAH

for LS-single seaters

Manual for the emergency bail out aid NOAH for LS-single seaters

Record of revisions

Any revision of the present manual, except actual weighing data, must be recorded in the following table and in case of approved sections endorsed by the responsible airworthiness authority.

The new or amended text in the revised page will be indicated by a black vertical line in the right hand margin, and the Revision No. and the date will be shown on the bottom left hand of the page.

Rev. No.	Affected Pages	Description	Issue Date
1	3, 8, 10, enclosure 1, Z139	Correction safety wire, NOAH refilling instructions	April 2008

Manual for the emergency bail out aid NOAH for LS-single seaters

Content

1. Description of the NOAH-system
2. Operating instructions NOAH
3. Maintenance instructions
 - 3.1 Annual inspection and service
 - 3.2 Service every 10 years
 - 3.3 Installation of the NOAH system
 - 3.4 Installation and removal of the pressurised gas cylinder for inspection
 - 3.5 Disconnecting the airbag from the pressure hose
 - 3.6 Filling the airbag for inspection purposes
 - 3.7 Folding and attaching the airbag
 - 3.8 Replacing Bowden-cables
 - 3.9 Seat harness buckle
 - 3.10 Life time of the NOAH components / spare part list
 - 3.11 Sending in for maintenance
4. List of tools
5. Materials for maintenance
6. Appendix
 - 6.1 List for annual weight measurement
 - 6.2 Drawings

NOAH general	Z150
Folding the airbag	Z99
pressurised gas cylinder with securing system	Z139
 - 6.3 Enclosure 1: NOAH refilling instructions

Manual for the emergency bail out aid NOAH for LS-single seaters

1. Description of the NOAH-system

NOAH is a system to facilitate the bail out of the cockpit in an emergency.

NOAH is a supplementation to the parachute.

NOAH features an airbag similar to a car airbag. The gas which is necessary to inflate the bag is stored in a pressurised gas cylinder. The actuation is by mechanical means, via a handle on the right hand cockpit wall near the canopy release.

To actuate NOAH the canopy must be opened or jettisoned first. The system is secured by a metal plate at the actuation unit which is blocked by a block at the canopy frame. The actuation handle is marked black and yellow.

A sticker is wrapped around the actuation handle and the guiding tube for the actuation cable. The sticker serves as an additional means to guard against inadvertent operation.



When the NOAH system is activated the seat harness buckle will be released prior to the opening of the pressurised gas cylinder. The pilot will be lifted by the airbag so that he can roll himself out of the cockpit.

If NOAH is used together with an automatic parachute, the emergency bail out procedure will be more or less automatic after operation of the NOAH handle.

Note: There is a small hole in the NOAH airbag at the front of the bag. In case of inadvertent inflation of the airbag gas can stream out of this hole. This is to prevent injuries to the pilot if the seat harness buckle is not open.

Technical data:

Mass of all parts: approx. 4,5 kg

Generation of pressure: nitrogen approx. 200 bar

Filling time: approx. 2 seconds

Design range: pilot mass 110 kg up to 4 g

General design see drawing Z150

Manual for the emergency bail out aid NOAH for LS-single seaters

2. Operating instructions NOAH

a) Pre-flight inspection

Check the airbag, the high pressure hose and the operating cables for correct positioning and for any wear.

Check especially if the nipple of the cable which opens the seat harness buckle is positioned **aft** of the cam of the actuation unit see sketch:

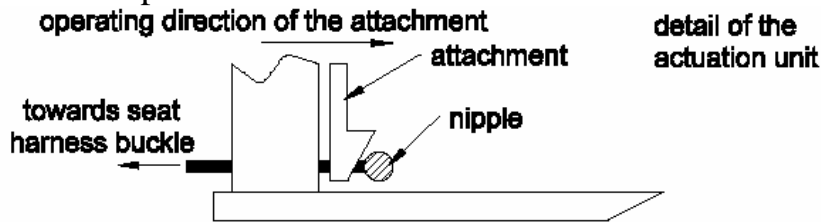

b) Use of NOAH in case of an emergency bail out:

Note: We recommend strongly the use of an automatic parachute. Only with an automatic parachute will the bail out procedure be nearly automatic and precious time and altitude can be saved.

For the bail out jettison the canopy first.

To do so firmly pull both red handles to their stops. The right handle operates the emergency canopy jettison. Lift canopy upwards at both red handles.

Warning: If there are loops at the rudder pedals make sure that your feet are out of the loops first.

Then pull the NOAH handle (at the right hand cockpit wall marked yellow and blyck) **strongly and quickly** up to its stop. Roll out of the cockpit by any means possible.

Note: Don't operate the NOAH handle on the ground with open canopy as you may release NOAH. When this happens the pressurised gas cylinder must be filled again and the airbag must be exchanged.

Note: For normal opening of the seat harness buckle rotate the buckle only in counterclockwise direction.

Manual for the emergency bail out aid NOAH for LS-single seaters

3. Maintenance instructions

3.1 Annual inspection and service:

1. Check if the pressurised gas cylinder is full: To accomplish this remove the cylinder from the glider see sect. 3.4 and weigh the cylinder. Compare the weight with the data on the placard on the cylinder. The balance must measure with a precision of 1g. If the weight is more than 5g lower than the first data on the placard, the cylinder must be sent in for refilling. Enter weight, date and inspection signature into the placard.
2. Check if the safety wire (item F on sketch in section 3.4.1, alternatively item D in section 3.4.2) is damaged. If the wire is damaged, the cylinder must be sent in for maintenance.
3. Visually check all parts assembled to the pressurised gas cylinder.
4. Visually check the airbag and the high pressure hose for any wear. Remove the cover of the airbag for this check.
5. Check the airbag for air-tightness see section 3.6.
6. Visually check all Bowden cables and the actuation unit for any wear and for corrosion.
7. Function check of the actuation unit (cylinder removed): Pull out the NOAH handle slowly and check the following items:
 - a) The seat harness buckle must fully release the seat harness approx. 10mm before the nipple of the Bowden-cable (running to the buckle) is inserted in the groove of the actuation unit see sketch.

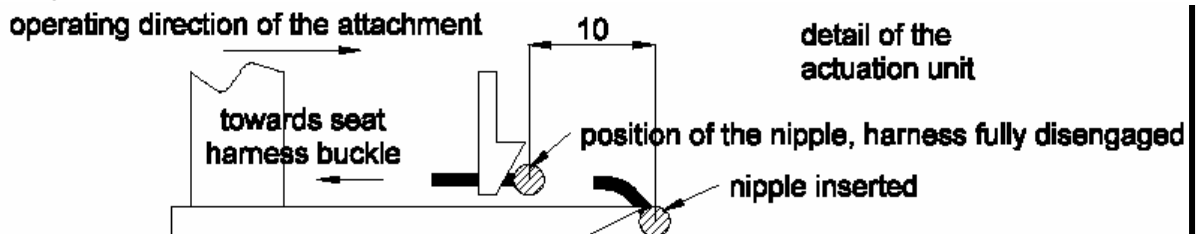

- b) The nipple of the Bowden cable must be inserted in the groove of the actuation unit before the seat harness buckle comes to its stop. The cable which runs to the pressurised gas cylinder shall not be tightened but have approx. 10mm freeplay (clevis pin in the slotted hole of the actuation unit).
- c) Move the cam of the actuation unit back to its initial position and release the nipple, the seat harness buckle must move back or must be turned back to its locked position.

Make sure that the nipple is positioned behind the cam, see sketch.

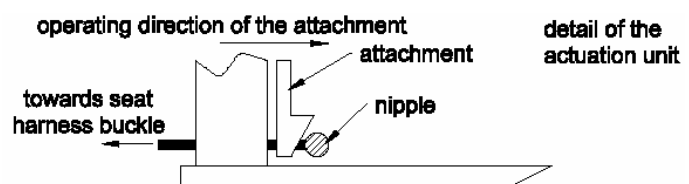

Manual for the emergency bail out aid NOAH for LS-single seaters

8. Maintenance: All parts are maintenance free. It is not allowed to oil or grease any part.
9. Assembly is in reverse order to removal. Fold the airbag according to section 3.7.
10. Use a new sticker and wrap it symmetrically around the handle and over the guiding tube of the operating cable. Press together both halves of the placard so that they stick together and to the guiding tube. The sticker serves as an additional means to prevent from inadvertent operation.



3.2 Maintenance every ten years

1. After 10 years the NOAH airbag and the high pressure hose have reached their lifetime limit. The pressurised gas cylinder must be inspected by a technical organisation approved for such inspections. As the pressurised gas cylinder must be emptied for this inspection you should use this opportunity for a complete test of your NOAH system.
2. Test: Buckle your seat harness, canopy open. Pull the NOAH operating handle **strongly and quickly** up to its stop. After the seat harness has opened the airbag should blow up in approx. 2 seconds.
3. To remove the gas from the airbag pull off the high pressure hose.
4. Remove the pressurised gas cylinder (see sect. 3.4), send in for inspection and refilling see sect. 3.11.
5. When you get the cylinder back install it together with the new airbag and high pressure hose. Execute items 2 and 4 up to 10 of the annual inspection see section 3.1. Enter the new parts in the record of life limited components of your glider.

3.3 Installation of the NOAH system

Install the system according to the installation instructions which belong to the technical note concerning the installation of the NOAH system into your glider type.

Enter the NOAH airbag, the high pressure hose and the pressurised gas cylinder into the record of life limited components of your glider.

Manual for the emergency bail out aid NOAH for LS-single seaters

3.4 Installation and removal of the pressurised gas cylinder for inspection

1 Remove the cover of the valve of the pressurised gas cylinder

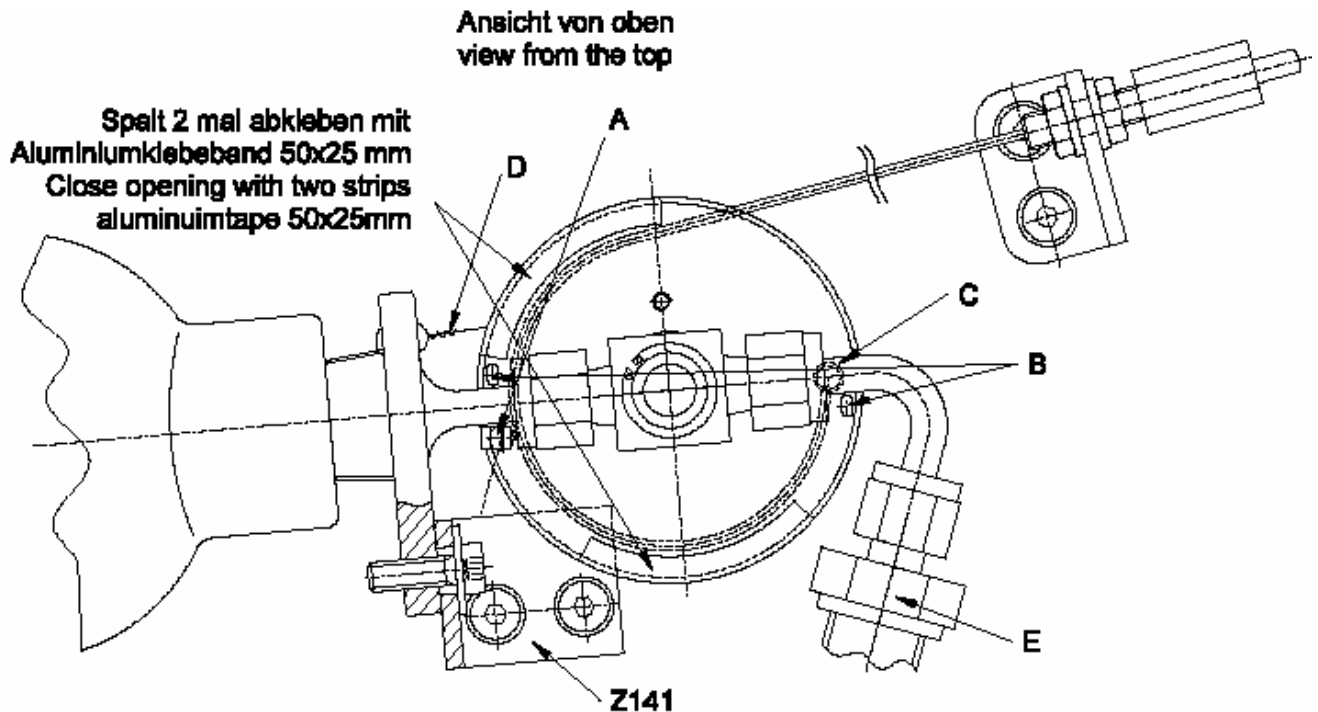

- 2 Install the transport securing device A (split pin 4x28 DIN94 St)
- 3 Remove the bowden cable. Therefore remove the split pin B (split pin 2x20 DIN 94 St) so that the nipple C can be taken out of the operating disc.
- 4 Remove the high pressure hose from the pressurised gas cylinder. Therefore unfasten the cap nut E (at the hose). (2 22mm open end spanners are needed).
- 5 Unscrew the angle Z141 and remove the pressurised gas cylinder.
- 6 Assembly is the reverse of removal. Apply new aluminium tape according to sketch, use new split pins B. Remove the transport securing device A when the system is completely installed.

Manual for the emergency bail out aid NOAH for LS-single seaters

3.5 Removal of the high pressure hose from the airbag

Pull out the U-shaped wire clip using universal pliers. Pull off the fitting from the airbag.

3.6 Filling the airbag for inspection purposes

Close the small hole (in the front of the airbag) with tape. Fill the airbag via the terminal of the high pressure hose. This must be done with a compressed air system which is equipped with a pressure reducer, a control valve and with a manometer (measuring range 0-0.5 bar).

To check the airbag for airtightness proceed as follows: Fill the airbag slowly, press onto the small hole with your finger in addition to the tape. Fill the airbag up to a max. pressure of 0,25 bar. Due to the design of the airbag some air may stream out of the airbag. Reduce the pressure to zero. After 30 seconds the amount of air which escaped from the bag should not be sufficient to noticeably change the shape of the inflated bag. Remove the tape from the hole.

3.7 Folding and attaching the airbag

Fix the airbag with Velcro strips to the seat shell. Then fold the airbag according to drawing Z99 and fix the cover with Velcro strips.

3.8 Replacement of Bowden cables

When replacing Bowden cables be sure to adjust the cables so that the correct sequence of all functions is ensured according to section 3.1 item 7 and the installation instruction of your glider.

3.9 Seat harness buckle

If the NOAH airbag has been inflated with the seat harness not opened, the seat harness buckle can be damaged. After such incidence the complete harness must be removed prior to the next flight and sent to its manufacturer for inspection and repair.

Manual for the emergency bail out aid NOAH for LS-single seaters

3.10 Life time of the NOAH components / spare part list

The NOAH airbag has a lifetime of 10 years. If the airbag was inflated in an emergency or inadvertently via the pressurised gas cylinder, the airbag must be replaced.

part-/drawing no.	description	life time
10180810	NOAH-airbag.	10 years
10181005	high pressure hose	10 years
10180806	sealing ring for high pressure hose connection 9,25X1,78	unlimited**
Z80	NOAH actuation unit	unlimited**
Z99/1	cover for NOAH airbag	unlimited**
Z139	pressurised gas cylinder with valve	unlimited ** inspection of the cylinder (every 10 years) according to TRG

** if no damage or excessive wear can be detected

3.11 Sending in for maintenance

Maintenance station:

DG-Flugzeugbau
Otto-Lilienthal-Weg 2
D 76646 Bruchsal
Germany

Refilling the NOAH pressurised gas cylinder or exchange of the safety wire:

For such work the NOAH pressurised gas cylinder must not be shipped to the Maintenance station. You may proceed according to enclosure 1 "NOAH refilling instructions"

Manual for the emergency bail out aid NOAH for LS-single seaters

4. List of tools

1. universal pliers
2. open end spanners 10mm, 2 pieces 22mm
3. socket wrench 7mm with extension
4. screw driver
5. Allen key wrench 3mm

5. Materials for maintenance

- split pin 2x20 DIN94 St (securing of the Bowden cable)
- split pin 4x28 DIN94 St (transport securing)
- Aluminium tape

6. Appendix

6.1. List for annual weight measurement

	Date	Weight of bottle	Inspection signature
1			
2			
3			
4			
5			
6			
7			
8			
9			
10			
11			
12			
13			
14			
15			
16			
17			
18			
19			
20			

Section/Schnitt C-C

Linke Cockpitseite (Left hand side of the cockpit)

FLUGRICHTUNG

alle Maße sind Prüfmaße

Auslöseeinheit nach Vorrichtung setzen

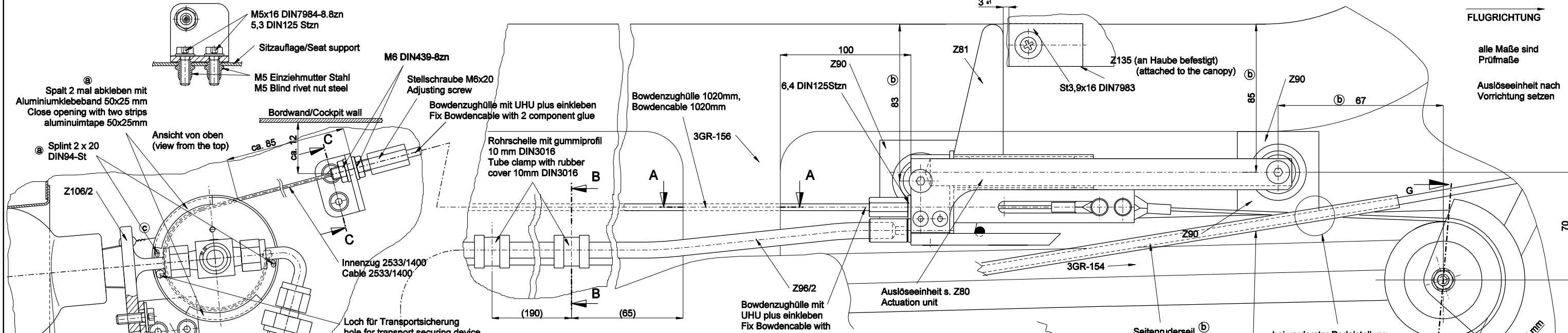

Section/Schnitt B-B

Section/Schnitt A-A

Lochverstärkung 2 x 92125 diag. Ø30mm
Reinforcement 2 x 92125 diag. Ø30mm

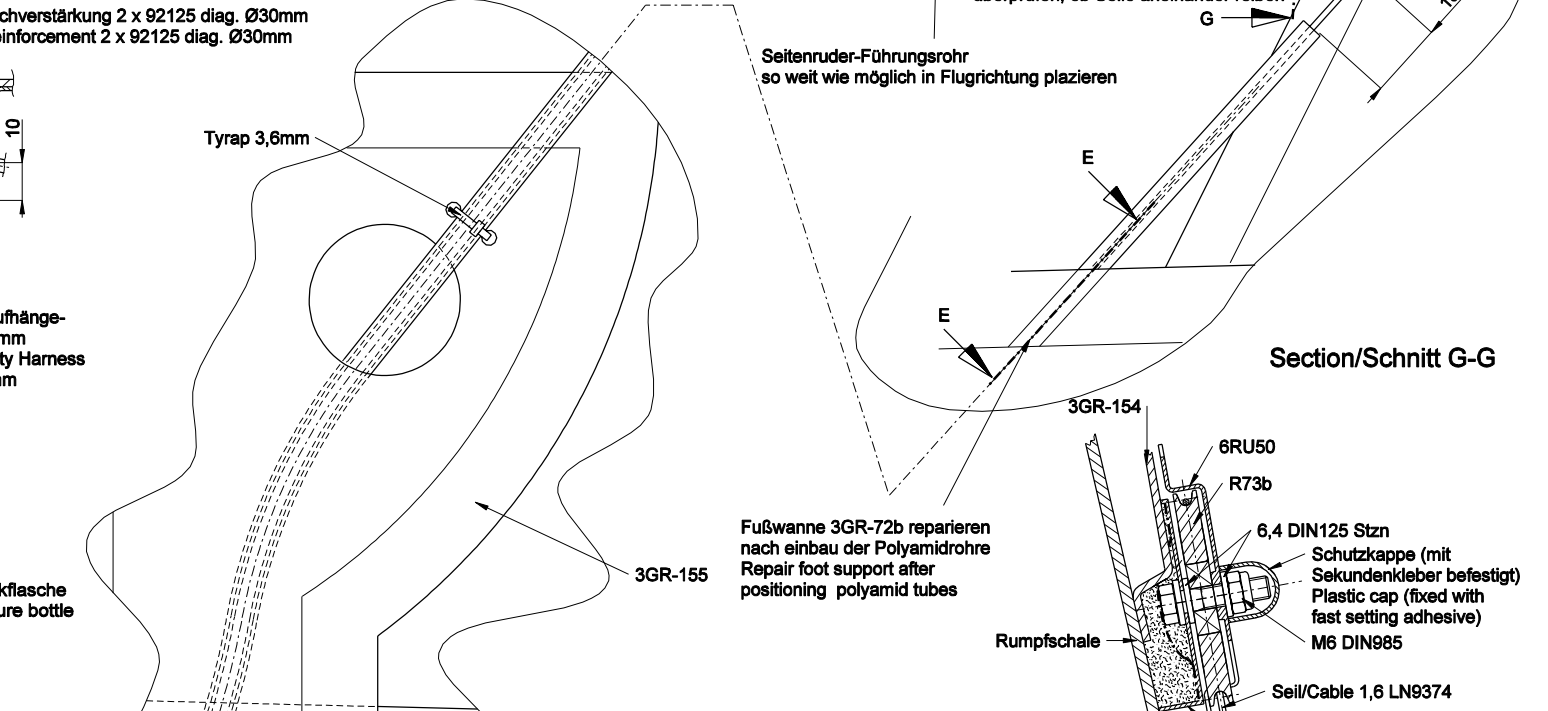
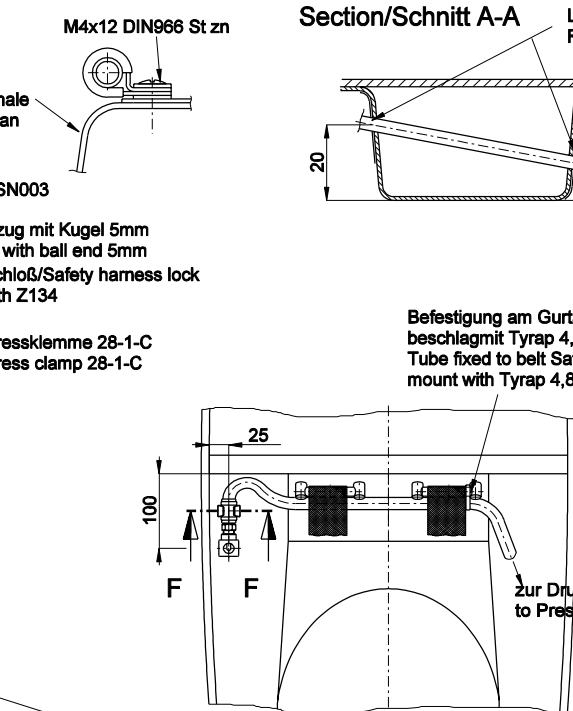
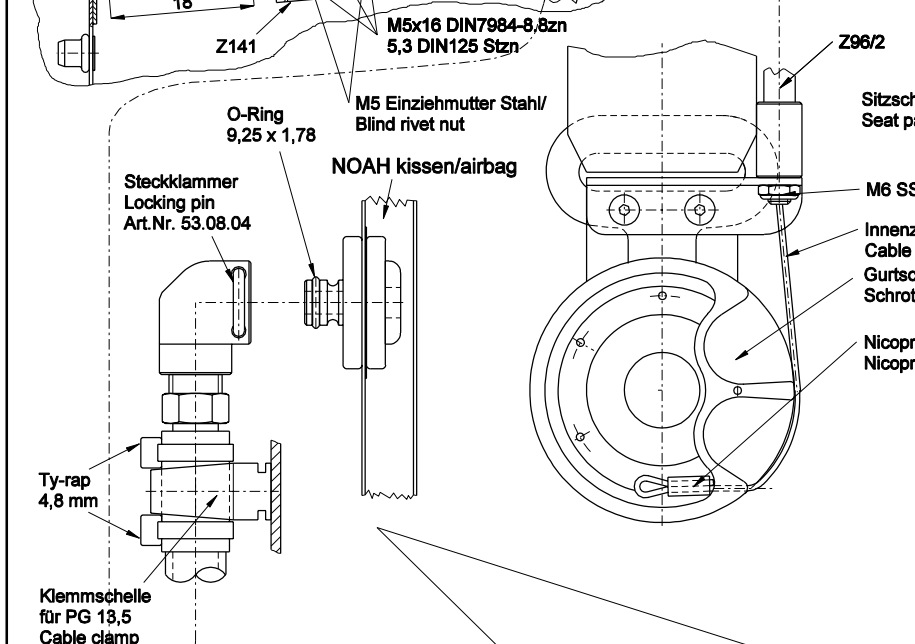

Section/Schnitt D-D

Section/Schnitt E-E

Section/Schnitt E-E

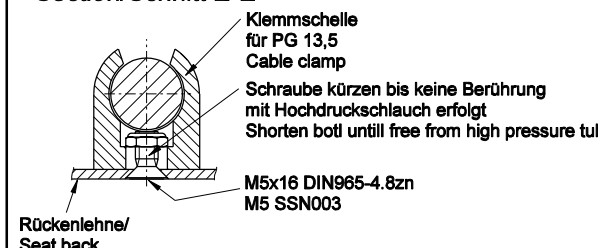
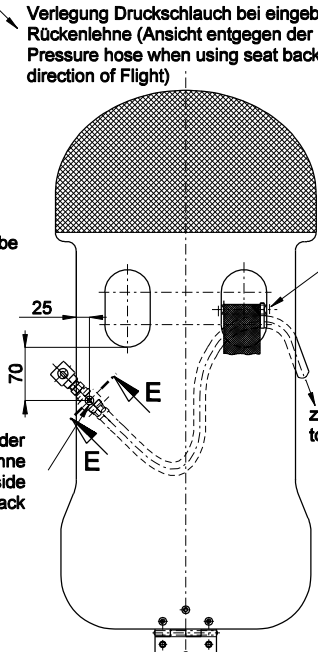

Section/Schnitt F-F

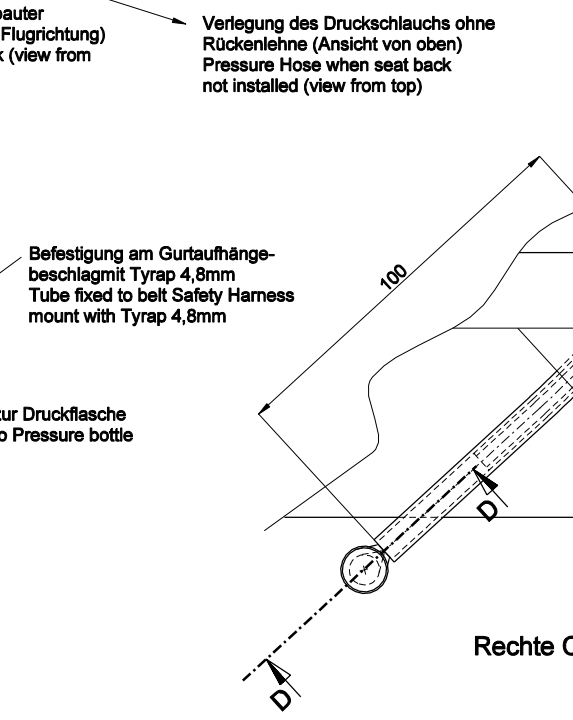
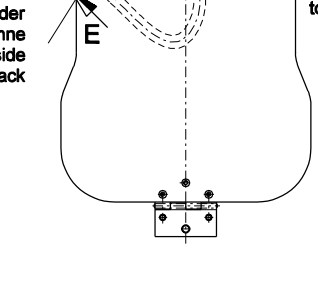
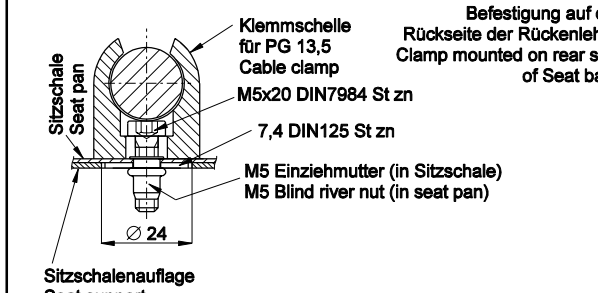

Rechte Cockpitseite (right hand side of the cockpit)

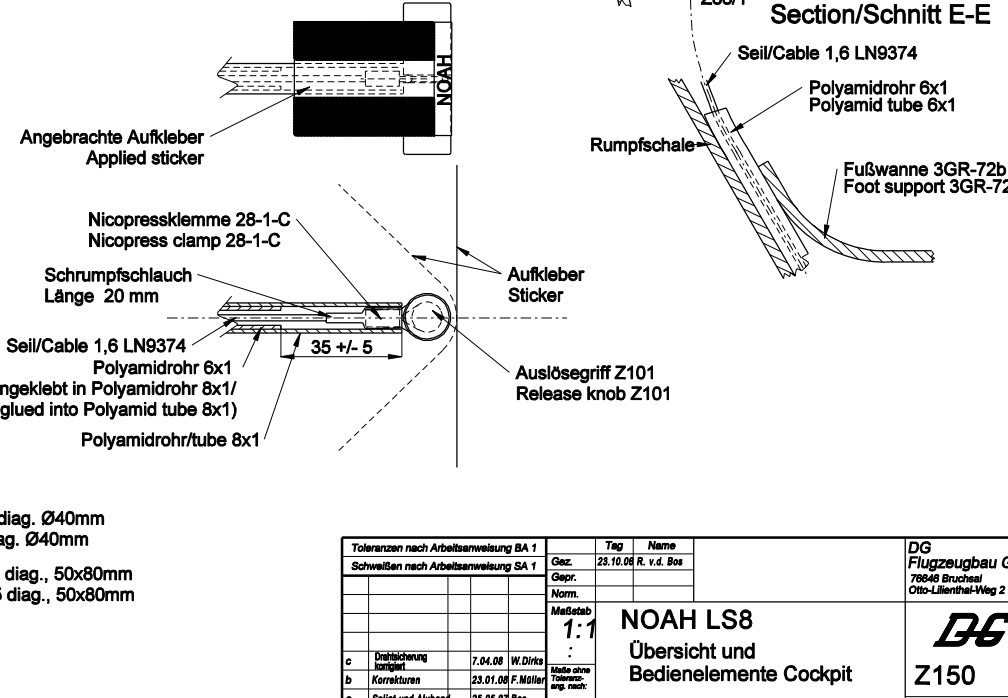

Toleranzen nach Arbeitsanweisung BA 1		Gez.	Tag	Name
Schweißen nach Arbeitsanweisung SA 1		Gepr.	28.10.08 R.	v.d. Bos
		Norm.		
		Meiße		
		1:1		
c	Drahtschönung Inhalt	7.04.08	W.Dirts	
b	Korrekturen	23.01.08	F.Müller	
a	Spilit und Alabend	25.05.07	Bos	
Ausg.	Änderung	AM	Tag	Name

NOAH LS8
Übersicht und
Bedienelemente Cockpit

DG
Flugzeugbau GmbH
78646 Bruchsal
Otto-Lilienthal-Weg 2

Z150

cover

Teil 1	Stück 1
Oberflächenschutz:	
Werkstoff: Polsterstoff	

Velcro tape 160 x 30
sewed to cover - upper side

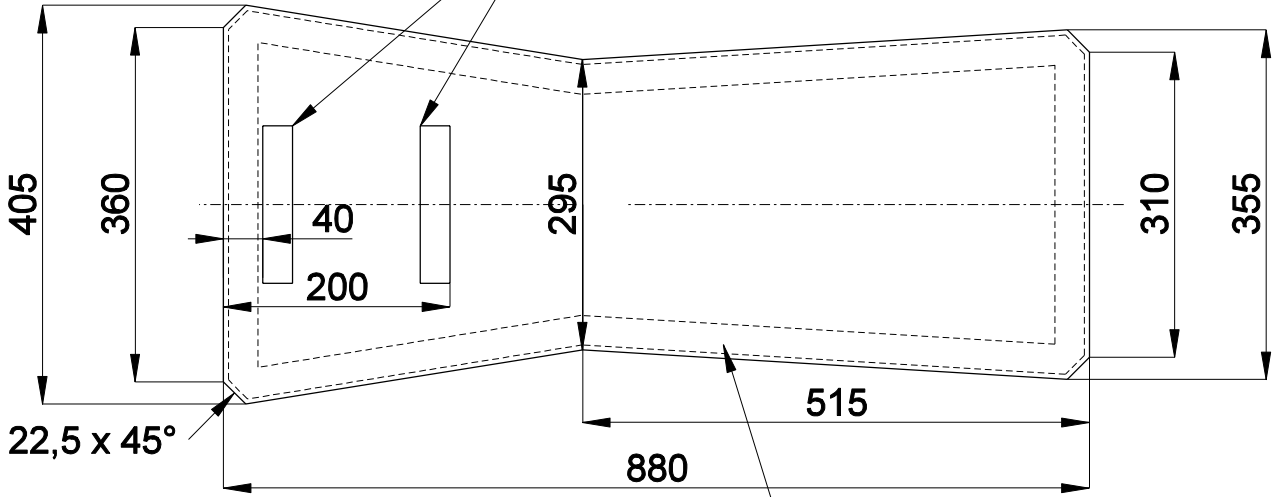

NOAH bag

Teil 2	Stück 1
Oberflächenschutz:	
Werkstoff:	

Velcro tape 2350 x 30
sewed to cover - lower side

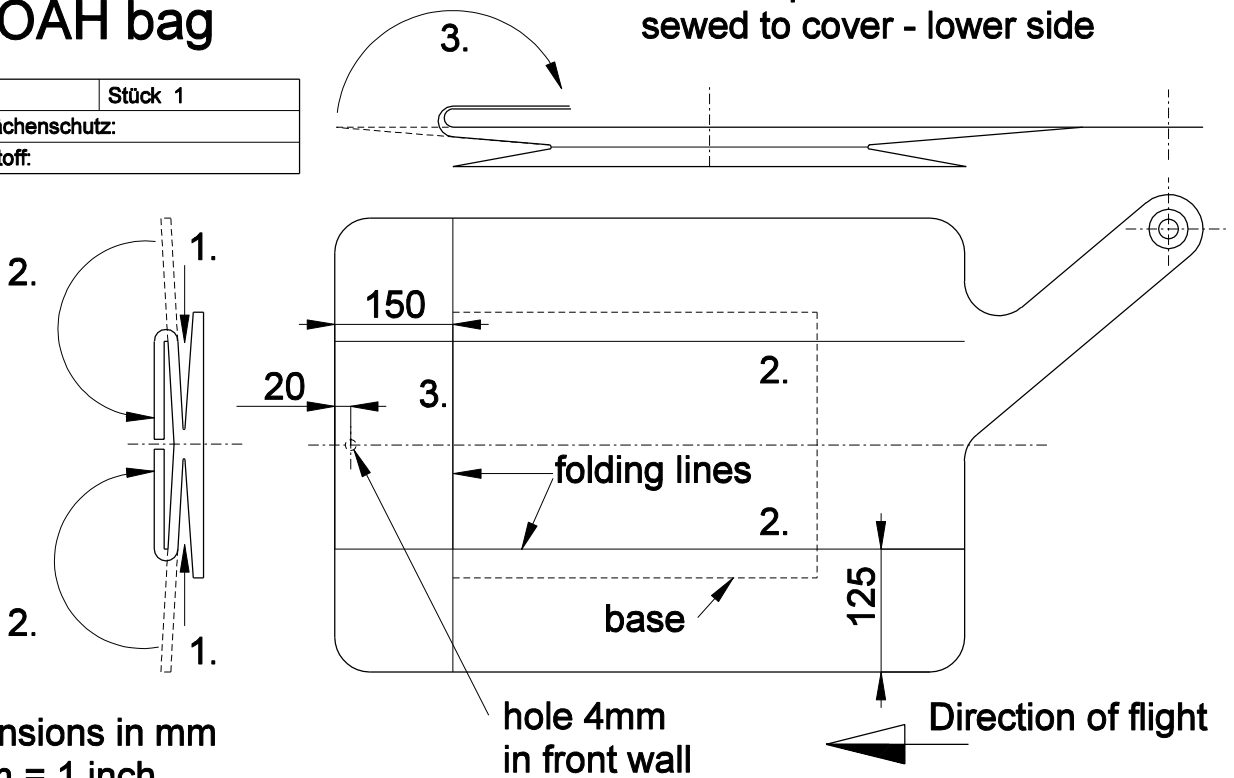

all dimensions in mm
25.4 mm = 1 inch

Toleranzen nach Arbeitsanweisung BA 1				Tag	Name	DG Flugzeugbau GmbH 76646 Bruchsal 4 Im Schollengarten 20	
Schweißen nach Arbeitsanweisung SA 1				Gez.	20.06.02 W. Dirks		
				Gepr.			
				Norm.			
				Maßstab	1:8	NOAH part 1 cover part 2 bag with folding instructions bag manufacturer cartrim	
					:		
				Maße ohne Toleranz- ang. nach:			
b	Teil 1 + Teil 2 neu	27.01.06	Henes				DG Z99
a	NOAH-Kissen bearb.	12.02.03	K.Thiel				
Ausg.	Änderung	ÄM	Tag	Name			

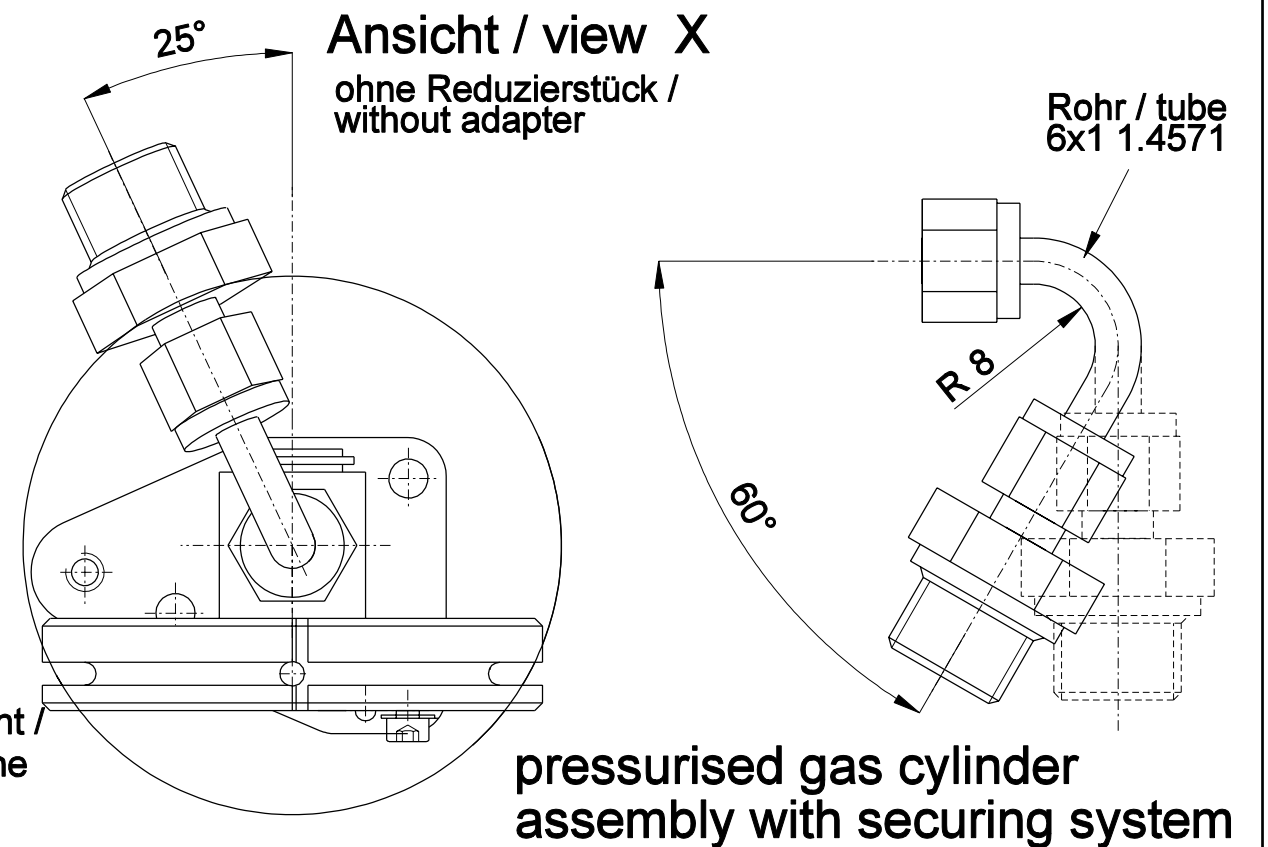
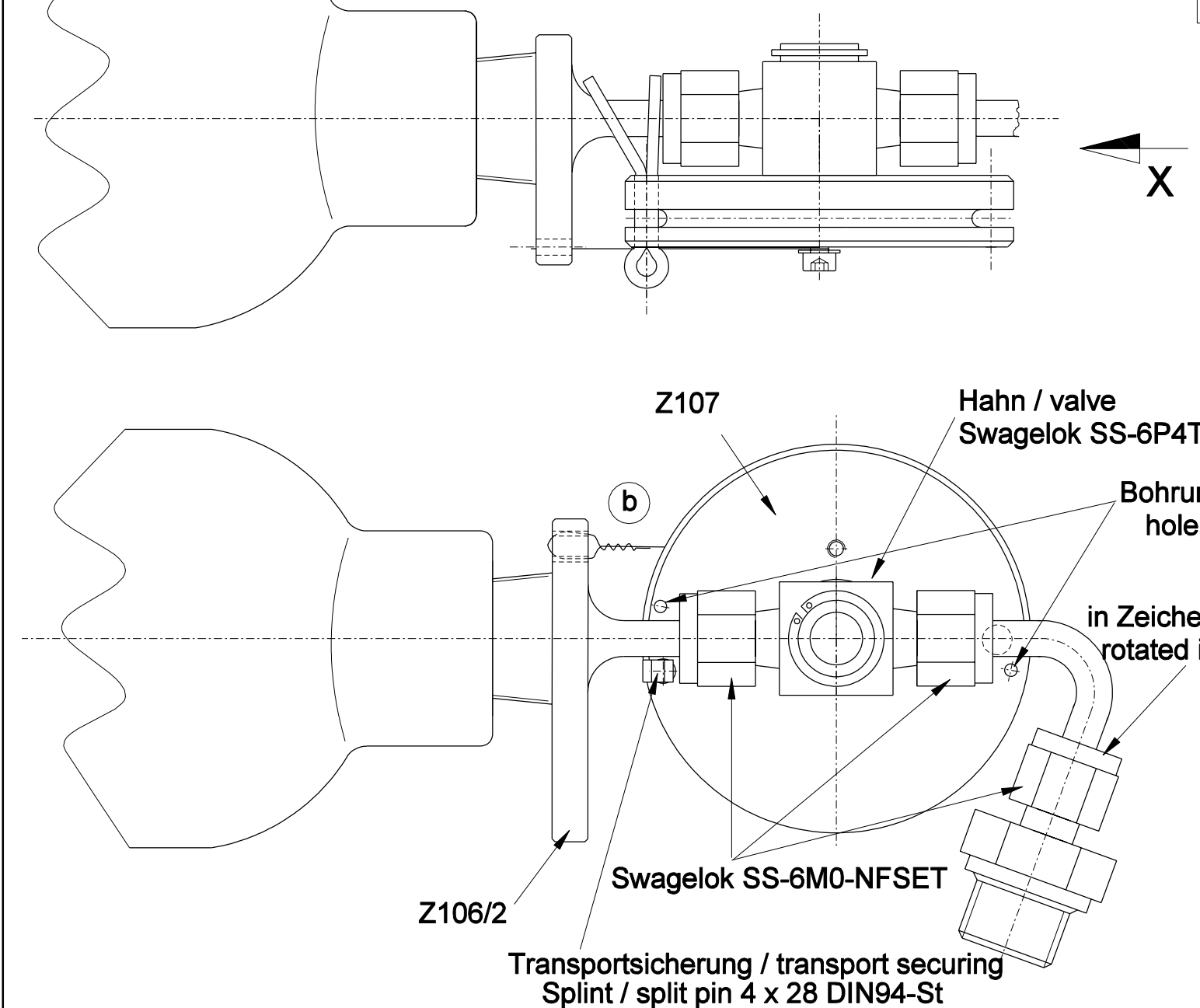
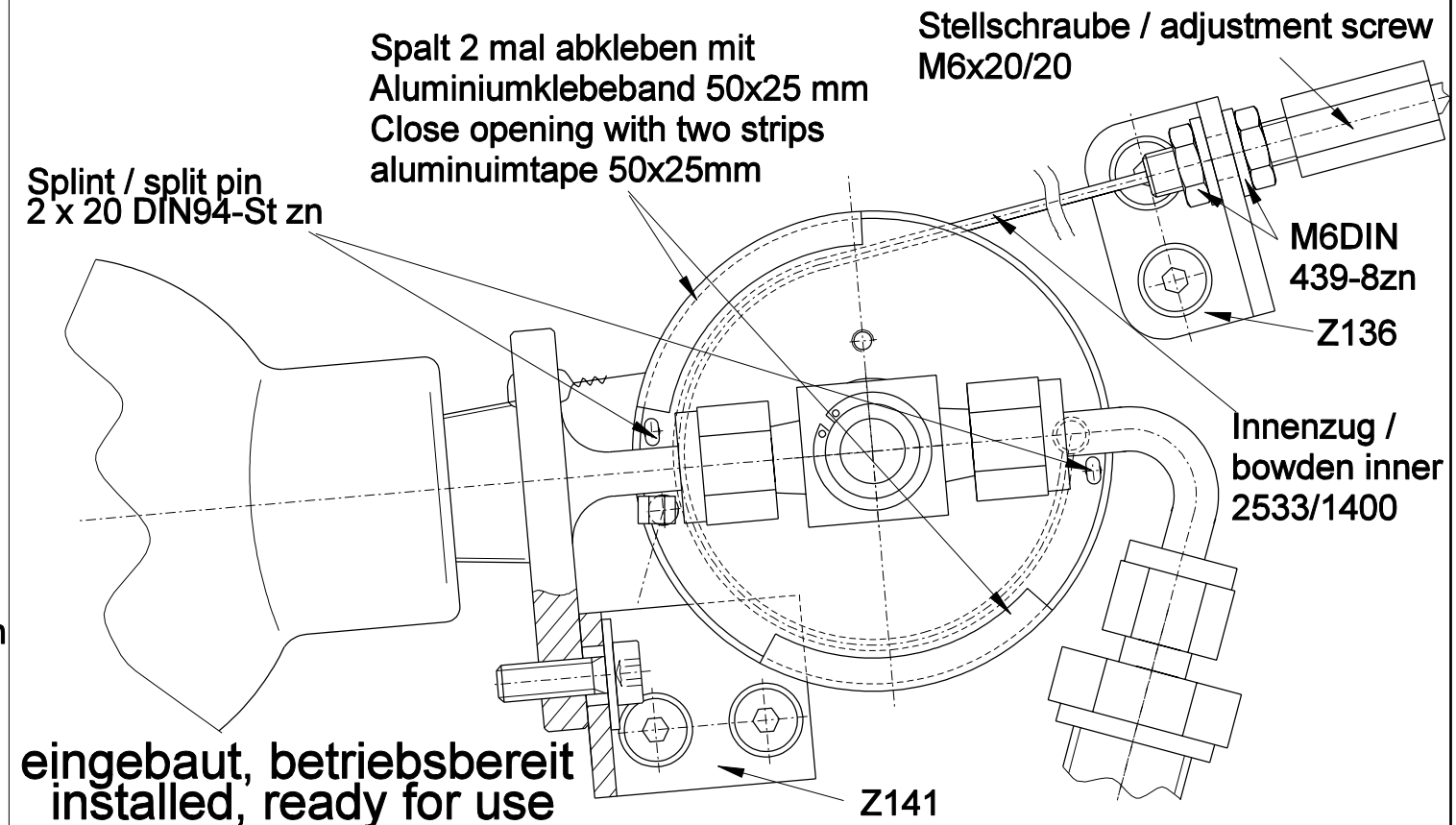
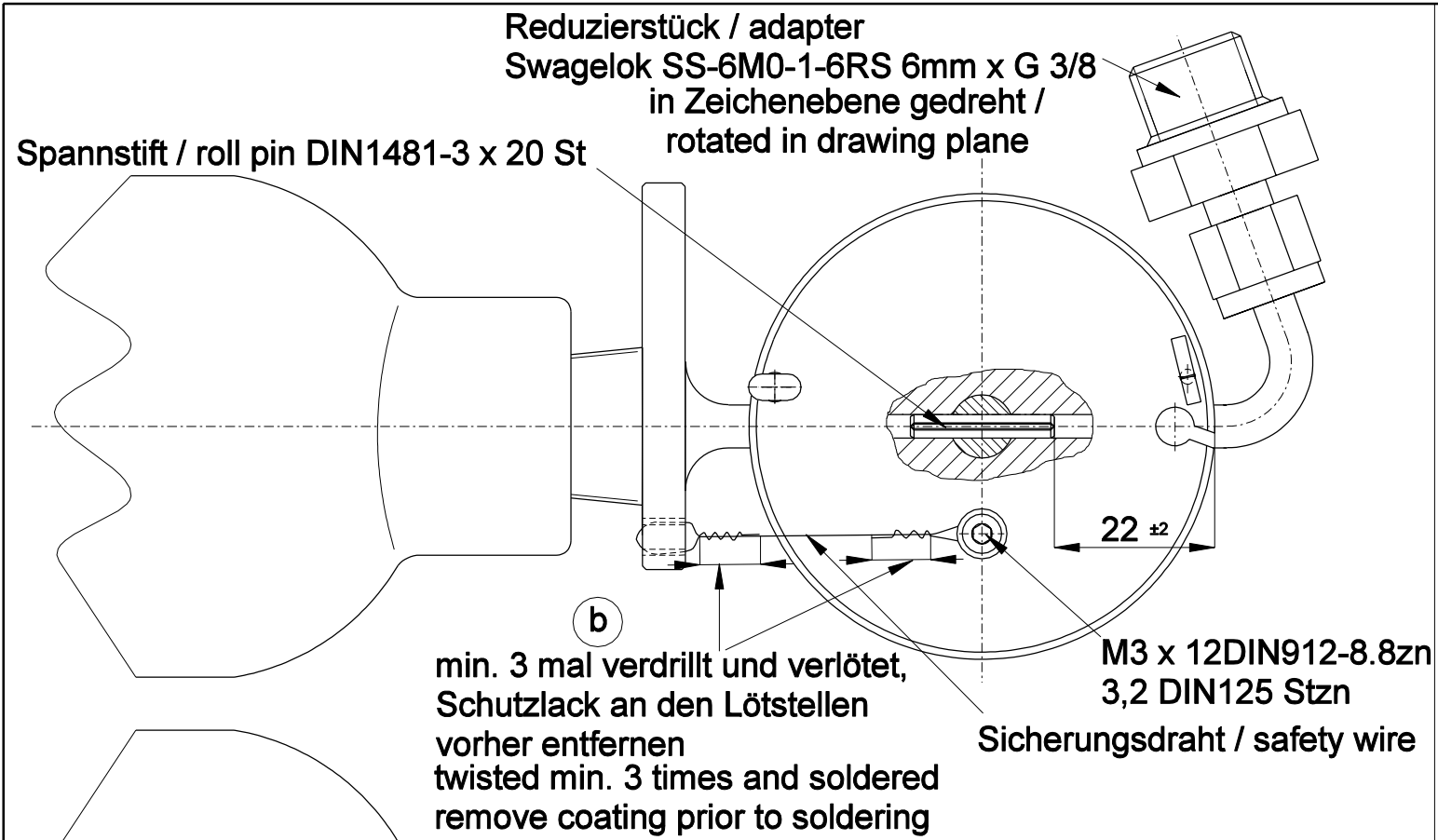

Toleranzen nach Arbeitsanweisung BA 1					Tag	Name	DG Flugzeugbau GmbH 76646 Bruchsal 4 Im Schollengarten 20
Schweißen nach Arbeitsanweisung SA 1					Gez.	17.10.03 R. Kern	
					Gepr.		
					Norm.		
					Maßstab	1:1	NOAH-LS Zusammenbau Druckgasflasche und Hahn mit Sicherung
					Maße ohne Toleranz- ang. nach:		
b	Drahtsicherung kompliert	3.04.08	W. Dirks				Z139
a	Splint statt Federstecker als Transp. Sicherung	30.11.06	v. d. Bos				
Ausg.	Änderung	ÄM	Tag	Name			

Refilling instructions

1. General

The pressurised gas cylinder should only be filled with water free nitrogen. If nitrogen is not available filling with dry- air is acceptable. A dry medium is essential to avoid icing during flights at high altitude, or temperatures below freezing.)

For refilling and inspecting a NOAH pressurised gas cylinder the following appliances are necessary.

1. Refilling station or large pressurised gas cylinder with min 220 bar (15.18 psi) pressure.
2. Adapter for the thread at the NOAH unit which is a cylindrical thread G 3/8.
3. Manometer (pressure gauge) measuring range up to 250 bar (17.05 psi).
4. Digital scale with 0,1g resolution.

2. Refilling

The Manometer should be installed between the valve at the NOAH pressurised gas cylinder and a second shut off valve in the line to the filling station.

After connecting the lines remove the screw which is fixing the safety wire to the disc on the valve and slowly open the valves at the NOAH unit and to the refilling station.

Fill up to 215 bar (14.84 psi). Close the valve to the refilling station.

At standard atmospheric pressure, the pressure in the NOAH pressurised gas cylinder must be 200 bar (13.8 psi).

During refilling the nitrogen or compressed air will raise its temperature and thus a higher filling pressure is needed.

After the NOAH pressurised gas cylinder has cooled down the pressure must be checked and further refilling to 200 bar may be necessary.

Out of experience a pressure of 215 bar is sufficient to reach 200 bar after cooling down.

Close the valve of the NOAH pressurised gas cylinder.

Remove the NOAH unit from the refilling station.

Weigh the NOAH pressurised gas cylinder and enter the weight into the placard on the cylinder.

3. Inspection after refilling

Leak test: Hold the NOAH unit with the valve down into still water (no air bubbles) which should be in a transparent container. The cylinder should be in the water up to its shoulder to detect any possible leaks.

Check for min. 5 minutes under water, in order to detect the slightest leaks. No leaks are permissible.

The weight of the NOAH pressurised gas cylinder must be rechecked after 2 weeks storage to detect very small leaks. The max. permissible weight reduction is 0.5 g.

4. **Sealing leaks**

Possible areas where leaks may occur:

- screwed joint of the valve to the flange of the NOAH pressurised gas cylinder Z106
- The valve
- screwed joint of the flange Z106 to the cylinder

If there is a leak at the screwed joint of the flange Z106 to the cylinder the cylinder must be emptied by slightly unscrewing the flange. Sealant “Hylomar” (a blue sealant used by Rolls-Royce produced under license by MARSTON Oelchemie) should be applied to the thread of the flange. Screw in the flange after 5 minutes curing time.

If the valve leaks it must be exchanged.

5. **Securing the valve of the NOAH pressurised gas cylinder**

The valve must be secured against inadvertent opening with safety wire according to the sketch below.

If the safety wire is still undamaged, reinstall the screw which is fixing the safety wire to the disc on the valve together with the safety wire. Secure the screw with red securing paint.

Otherwise a new safety wire must be installed. Only the prefabricated safety wire DG part no. 10180843 is approved and must be obtained from DG Flugzeugbau.

Other safety wire may make the opening of the NOAH pressurised gas cylinder by the pilot impossible.

